

NORITZ® **MAINTENANCE & TROUBLESHOOTING**

Level 2 Troubleshooting and Service,
Focused on the EZ, NRCR and CDV.



1



OUTLINE

We will cover the following topics:

- Recommended Tools
- Water Quality & Descale Procedure
- General Service & Maintenance
- Common Error codes and Maintenance Monitors
- ½" Gas Line Requirements
- Component Identification
- PROCard App



2

RECOMMENDED TOOLS

What's in your tool bag?



3

RECOMMENDED TOOLS

While you *can* fully disassemble and reassemble a Noritz unit with only a long phillips screwdriver, you may not be able to complete all service or troubleshooting with *only* a screwdriver. A T15 Torx bit, flashlight and plumbers grease are also helpful to round out your tool kit.

- Phillips Screwdriver
- Descale Kit
- Digital Gas Manometer
- Digital Multimeter
- Air Compressor
- Noritz Remote Control



4

WATER QUALITY AND DESCALE PROCEDURE

Ensure a long life by addressing water quality issues per our guidelines.



5

WATER QUALITY GUIDELINES

Water Quality Guidelines in the Installation Manual should always be followed. Softening or treating the water with a Scale Shield is best as it prevents scale build up from happening in the first place. Descalers are good, but a last resort as you are cleaning up scale build up that could have been prevented.

Damage to the water heater as a result of the items below is not covered by the Noritz America Limited Warranty.
 • Water in excess of 12 gpg (200mg/L) of hardness
 • Poor water quality (See the Water Quality List on page 34.)
 • The water heater has displayed a "C1#" (Service Reminder) indicating Scale Build-up, but the heat exchanger has not been flushed.

Treatment Guidelines

Type of Water	Hardness Level	Treatment Device*	Flush Frequency** Residential Use
Soft	0-1 gpg (0-17 mg/L)	None	None
Slightly Hard	1-3 gpg (17-51 mg/L)	None	None
Moderately Hard	3-7 gpg (51-120 mg/L)	ScaleShield or Water Softener	Once a Year***
Hard	7-10 gpg (120-171 mg/L)	ScaleShield or Water Softener	Once a Year***
Very Hard	10-12 gpg (171-200 mg/L)	ScaleShield or Water Softener	Once a Year***
Extremely Hard	> 12 gpg (> 200 mg/L)	ScaleShield or Water Softener	Once a Year***



* When selecting a treatment device, you must consult with the device's spec sheet and installation manual for guidelines and limitations. Not all water supplies are compatible - a water test may be required.

** Install Noritz Isolation Valves to allow for flushing.

*** Flushing is required if a water treatment device is not installed.



6

WATER QUALITY GUIDELINES

Here are some issues related to Hard Water or Poor Water Quality:

- ⚠ Scale Buildup
- ⚠ Heat Exchanger Leak
- ⚠ Unstable Water Temperature
- ⚠ Clogged Inlet Filter Screen



7

WATER QUALITY GUIDELINES

All* units since 2016 have a “Flush Mode” used when descaling the unit.

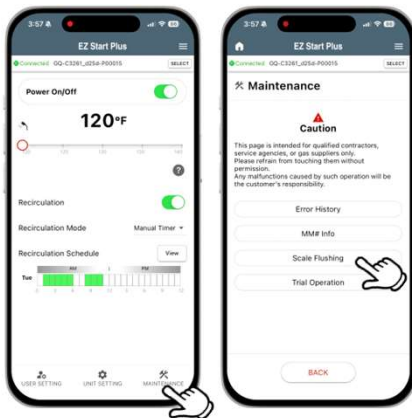

PRO Series Models



Directions can be found in the manual



2016+ Models NORITZ

*NC380-SV Does not have a flush connector.

8

DESCALE EQUIPMENT

So, what do you need to perform a proper descale?



Noritz Descale Kit Shown, Part # DSCL-KIT



9

DESCALE DIRECTIONS

<http://support.noritz.com>



PROCard App

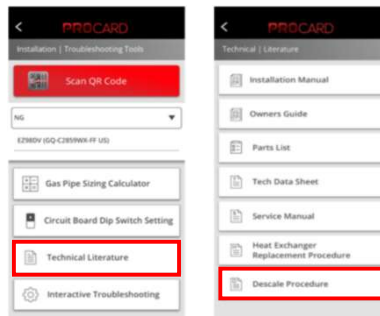

[Youtube.com/Noritzamerica](https://www.youtube.com/Noritzamerica)



10

GENERAL SERVICE AND MAINTENANCE

Periodic maintenance items to keep the unit running at peak performance



11

MAINTENANCE ITEMS

A descale takes 1 hour, that's the perfect time to look over the unit and clean any areas that are dirty.

This could include:

- Checking intake and exhaust terminations
- Checking internal intake filter
- Cleaning ignition and flame rods
- Cleaning fan motor and burner

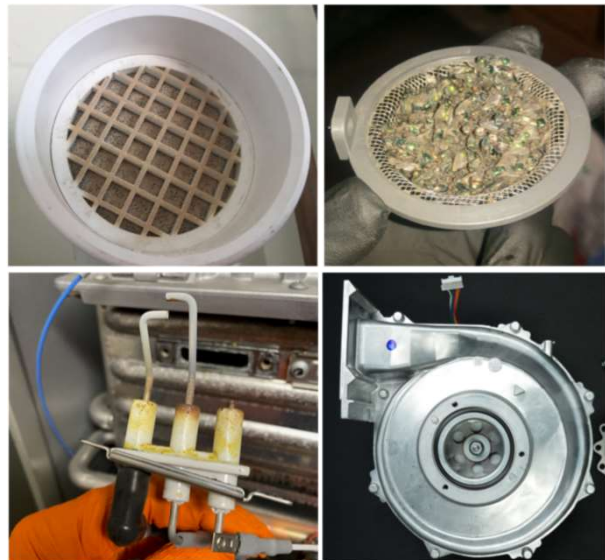

12

CLEANING IGNITION & FLAME RODS

Remove 2 screws securing rods

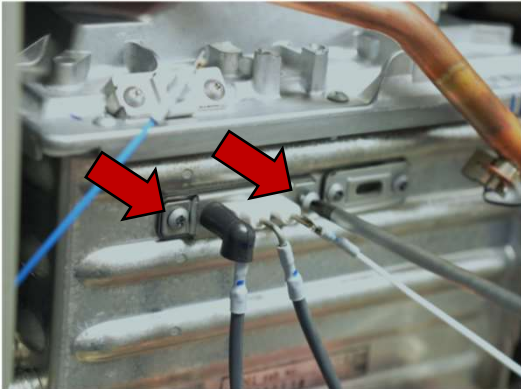

Clean with rough side of a sponge, Scotch-Brite pad, fine grit sandpaper (300+ grit)



 NORITZ®

13

CLEANING FAN & BURNER

SHUT OFF GAS then remove mounting bracket (2 screws)

Scan
Here!

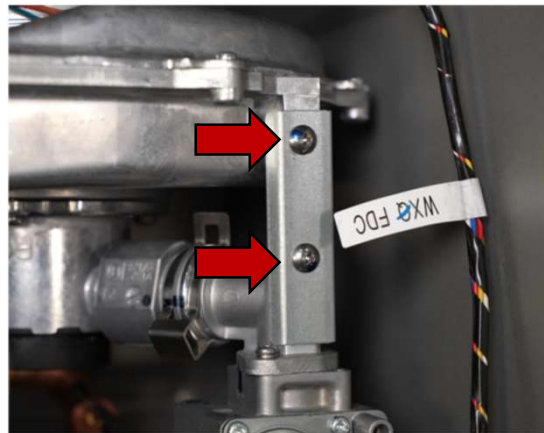

 NORITZ®

14

CLEANING FAN & BURNER

Remove c-clip and carefully disconnect gas valve from venturi. There is an o-ring, be careful not to damage it.

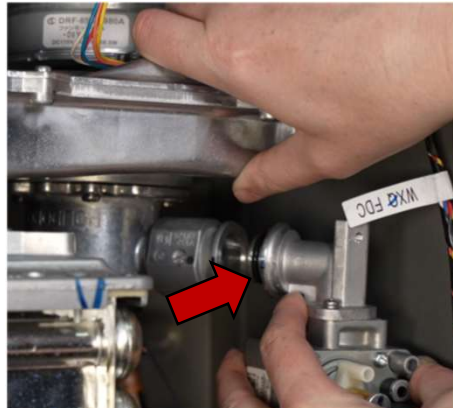
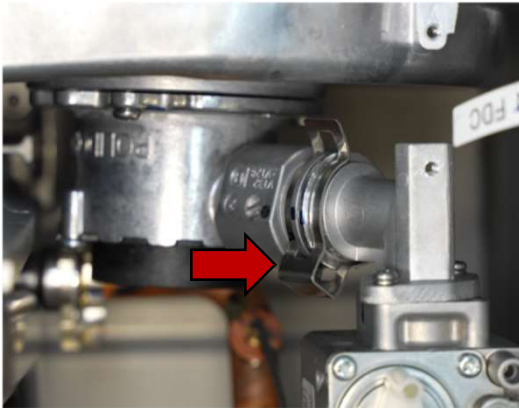

15

CLEANING FAN & BURNER

Disconnect fan wire harness then remove 4 screws securing it to burner.

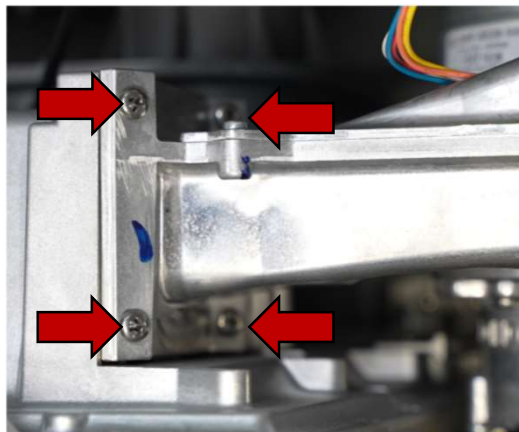

16

CLEANING FAN & BURNER

Remove fan motor and venturi from unit and remove venturi from fan.

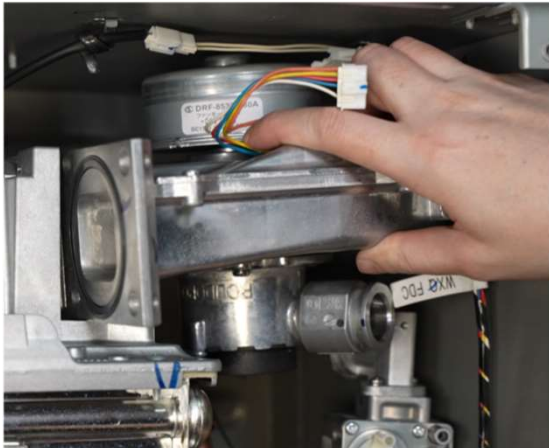

17

CLEANING FAN & BURNER

Clean the fan with an air compressor, vacuum, plastic brush or any combination of those items. If the fan cannot be cleaned effectively, the fan should be replaced. **DO NOT SPLIT THE FAN HOUSING.**

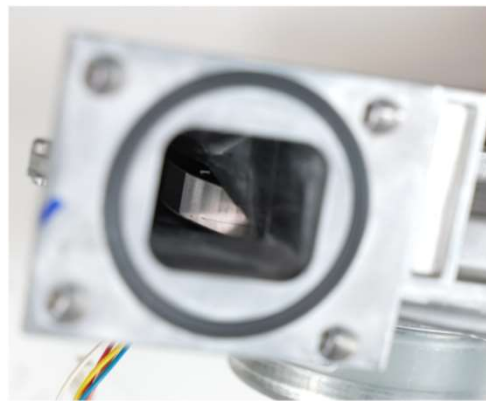

18

CLEANING FAN & BURNER

When reassembling, line up the gas connection with the triangle stamped on the fan housing. Be careful not to damage or lose any o-rings or gaskets on the fan housing.

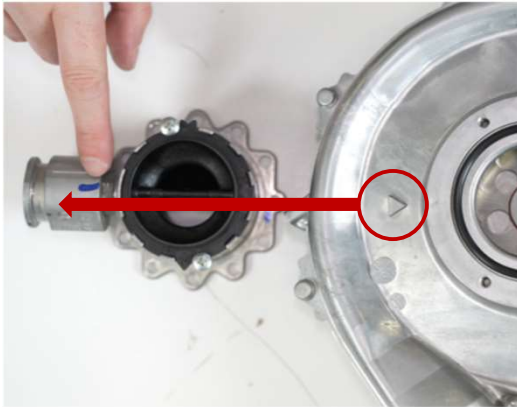

19

CLEANING FAN & BURNER

Use a vacuum to clean the burner. **DO NOT USE AN AIR COMPRESSOR ON THE BURNER!** The burner mesh could be damaged and cause additional problems.

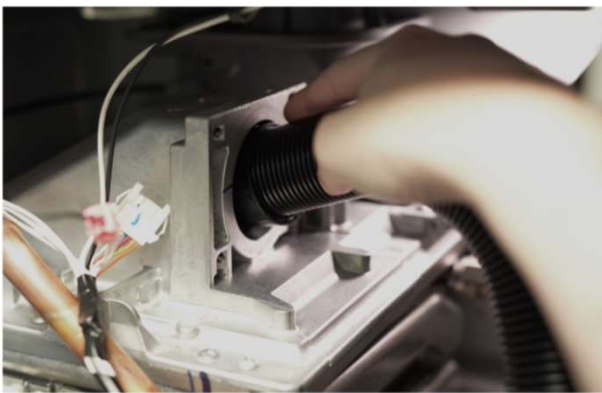

20

COMMON ERROR CODES



21

COMMON ERROR CODES

Error Code	Description
11	Ignition Failure (Failure to detect flame)
12	Flame Loss
16	Abnormally High Outlet Temperature
20	High Limit Switch
63	Recirculation Abnormality
65	Main Water Control Servo Abnormality
66	Bypass Water Control Servo Abnormality
73	Circuit Board Setting Abnormality
F76	Multi System Communication Error
90	Combustion Abnormality



22

TECHNICAL DATA SHEET

This sheet is inside a zip bag taped to the inside of the front cover and gives you the most commonly requested technical data.

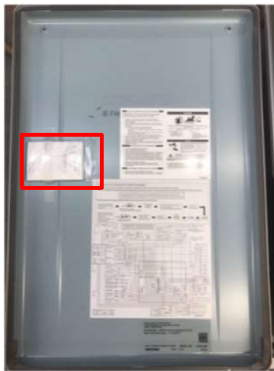

Technical Sheet

Models	EZ111DV(GQ-C3260WX-FF US)
	EZ98DV(GQ-C2860WX-FF US)

Components

EZ111DV(GQ-C3260WX-FF US)
EZ98DV(GQ-C2860WX-FF US)

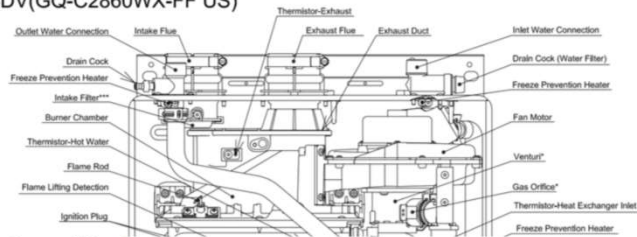

Error Codes and Checkpoints

Display	Description	Diagnosis Point (Trouble Point)	Remarks
FF 10	Combustion abnormality (Only memorized in error code history)	Check air supply vent for blockage or obstruction. Check exhaust vent for blockage or obstruction. Have a professional check the gas supply pressure. Check if the thermistor is open or is damaged or frozen.	
FF 11	Ignition failure (Initial flame out)	Circuit board. Check points (Check the wiring diagram behind the front cover)	Normal value
FF 12	Flame flow error		

Circuit Board Checkpoints

Ref. No.	Part	Circuit board. Check points (Check the wiring diagram behind the front cover)	Normal value	Remarks
1	Water Sen			

Maintenance Monitor List

Date No.	Item	Minimum Value	Remarks
01	Total Flue		
02	Total Combu		
03	Total Combu		
04	Number of Ign		

Dip Switch Settings

Disconnect the electrical power to the water heater before adjusting the Dip Switches.

[Dip Switches]



- The following settings can be adjusted using the Dip Switches:
- To set up with the common vent system, SW 1 needs to be turned on.*
 - By using SW 2 and 3, it can adapt to the setting of the exhaust type.**
 - By using SW 5 and 6, adjustments can be made for use at high elevation.
 - By using SW 7 and 8, adjustments can be made for extended vent lengths. Refer to the "Setting list for Dip Switches" table for details.



EZ START PLUS ERROR HISTORY



Error history can be displayed, and content can be emailed to Noritz Customer Care.

Tap on the error code to link to the Noritz web site. Detailed error code info displayed.

Shows the number of days elapsed since the error was reported.

Tap the email icon to launch the email app to send data to Noritz Customer Care.



Tap Maintenance Button

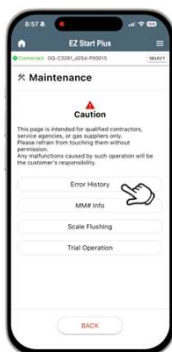

Tap Error History Button

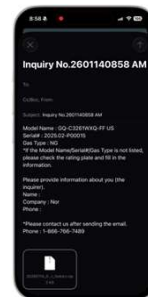
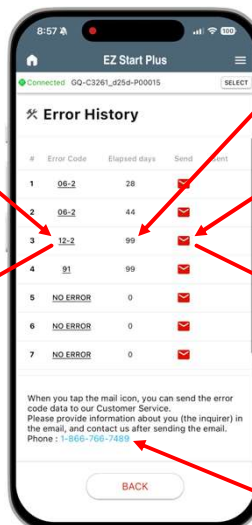
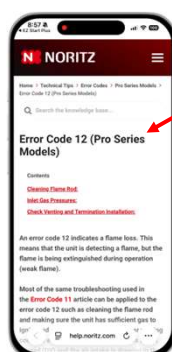

Tap the phone # to launch the phone app and call Noritz.

11 ERROR CODE

11 Error Code: Ignition Failure (Failure to Detect Flame)

This code indicates a lack of spark or lack of gas entering the burner. Three things needed for combustion are:

- ➔ Air
- ➔ Fuel
- ➔ Spark

Model:	NG	LP
EZ, NRRCR, NCC199CDV	3.5" to 10.5" WC	8" to 14" WC



However, you can cross off Air as a cause by simply removing the front cover. Start simple with troubleshooting, don't jump to the most complicated possibility. Simple steps like verifying inlet gas pressures are within range and cleaning the ignition rods.



25

12 ERROR CODE

12 Error Code: Repeated Flame Loss

This code indicates the unit cannot maintain flame in the burner. Just like the error code 11, insufficient inlet gas pressures can also cause the flame to go out.

Model:	NG	LP
EZ, NRRCR, NCC199CDV	3.5" to 10.5" WC	8" to 14" WC

Verify Inlet Pressure



Check/Clean Flame Rod



Check Grounds

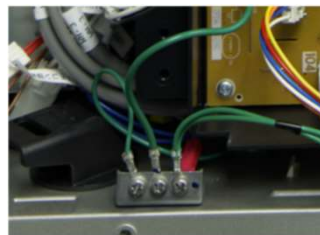

Incorrect Venting



26

16 & 20 ERROR CODES



16 Error Code: Abnormally High Output Temp

- Scale deposits in the heat exchanger and/or water components
- Wrong gas type

20 Error Code: High Limit Switch

- Scale deposits in the heat exchanger
- Poor Combustion
- Bad Wiring or Failed High Limit Switch

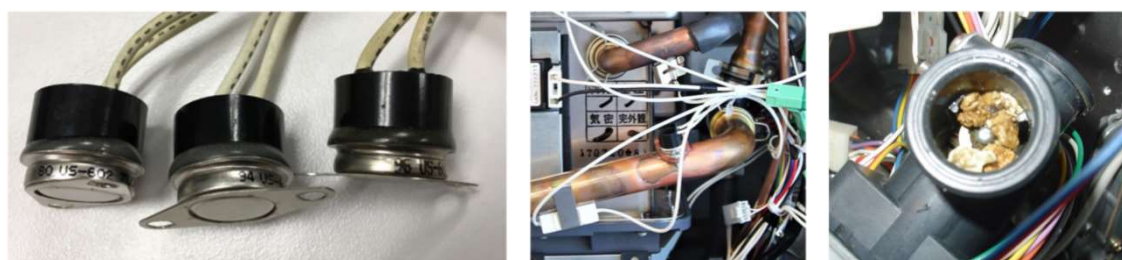

27

63 ERROR CODE

63 Error Code: Recirculation Abnormality (NRCR Only)

This code indicates the unit is trying to run the recirculation pump but is not detecting any flow.

New Installations:

- Check Return Line Filter and Water Shut Offs
- Purge air in the domestic hot and return line (Dedicated Mode)
- Check that the "Crossover" connector is connected together
- Check crossover valve filter (Crossover Mode)

Older Installations:

- Check Return Line Filter and Water Shut Offs
- Circuit Board
- Recirc Pump
- Recirc Flow Sensor



Scan Here!

Recirculation Pump Voltage Check		
Connector	Pin	Wire Color
CN 1	#2	Black
CN 42	#3	White

Expected Voltage When Pump is Running:
AC 108 - 132 V



28

65 & 66 ERROR CODES

65 Error Code: Main Servo Abnormality

66 Error Code: Bypass Servo Abnormality

Both error codes indicate a problem communicating with or positioning the respective water servo.

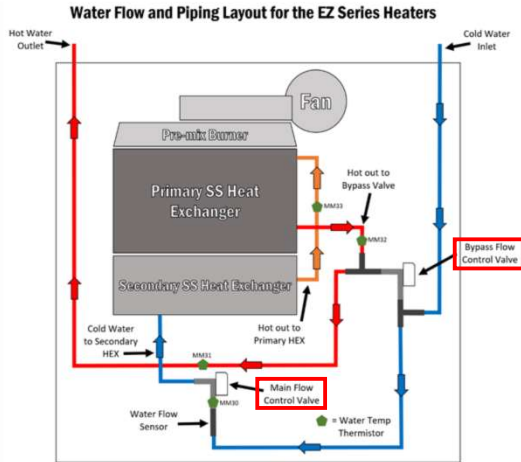

29

73 & F76 ERROR CODES

73 Error Code: Circuit Board Setting Abnormality

If dipswitches were changed or other connectors changed while unit has power a 73 code will appear. Unplug unit, finalize all dipswitch and wiring changes, and plug in heater.

Also occurs if the circuit board was replaced but not programmed.

F76 Error Code: Multi System Communication Error

Make sure only 1 remote control is hooked up when there are 2 units quick connected.



System Diagram

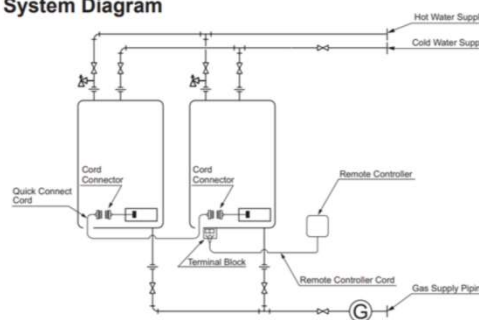

* When connecting two units, use only a single remote controller.

Note: Connect the remote controller to only one of the units. Units must be same model in order to quick connect.



30

90 ERROR CODE

90 Error Code: Combustion Abnormality

This code indicates the unit is not able to hit the set temperature.

Most commonly caused by restrictions in the venting (intake and/or exhaust), incorrect dipswitch settings, a clogged or restricted condensate drain line or insufficient gas pressure going to the unit.

Older installs may have a dirty fan or venturi reducing the amount of air and gas that makes it into the burner.

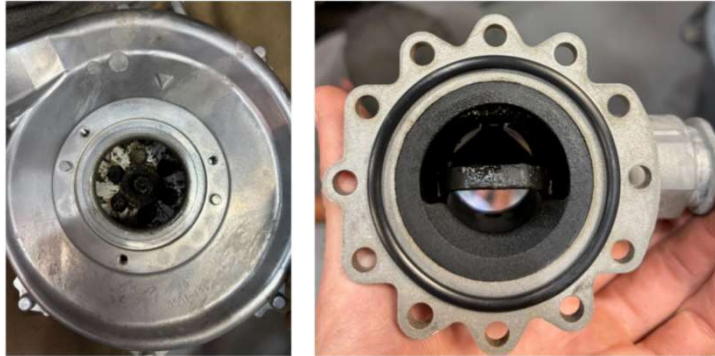

31

90 ERROR CODE

90 Error Code: Combustion Abnormality

Use the PROCard App to verify correct dipswitch settings.

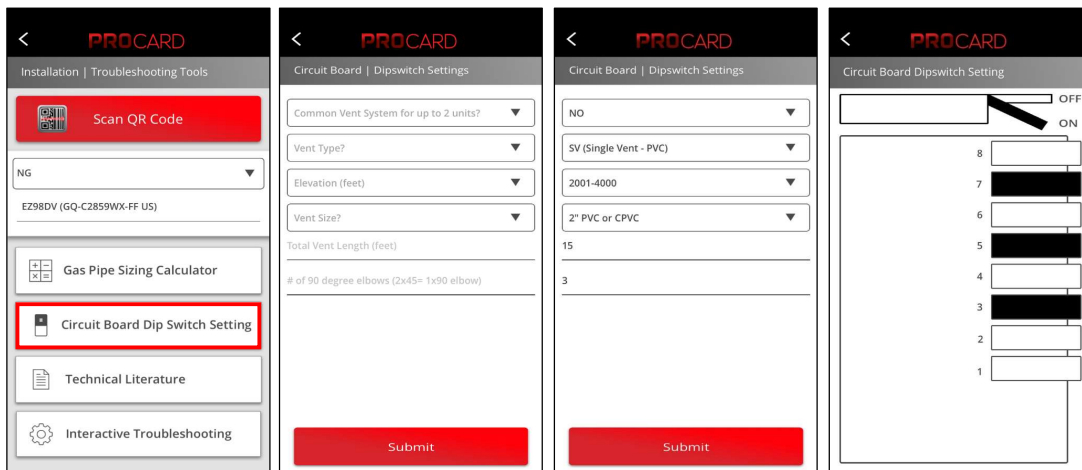

32

90 ERROR CODE

90 Error Code: Combustion Abnormality

Use the EZ Start Plus App or Operation Panel to verify correct settings.

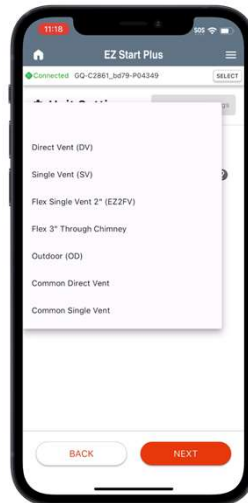

33

LESS THAN IDEAL INSTALLS



34

COMMON MAINTENANCE MONITORS



35

MAINTENANCE MONITORS

Commonly used maintenance monitors for troubleshooting and service

MM14: Flow Rate

MM30: Inlet Water Temp

MM31: Outlet Water Temp

MM32: Heat Exchanger (HEX) Water Temp

MM86: Recirculation Mode (NRCR)



Scan
Here!

Residential Remote



Commercial Remote



36

EZ START PLUS MAINT MONITORS



You can check and record up to 2 minutes of Maintenance Monitor data and send to Noritz Customer Care.



Tap Maintenance Button

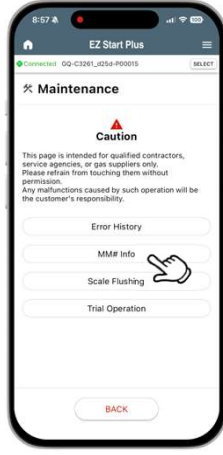

Tap MM# Info Button

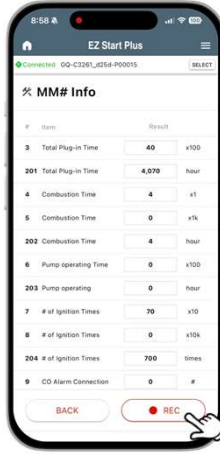

Tap REC Button

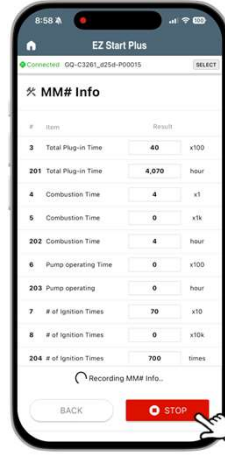

Tap STOP Button or 2 minutes passed

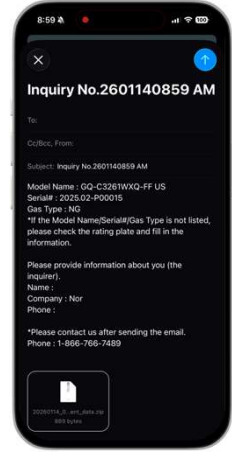

Auto launches email after recording ended

37

MM14 FLOW RATE

Tankless heaters activate and remain on based on a minimum flow rate (usually .5 gallons per minute [gpm]).

Units are on demand and they modulate in real time based on the following conditions:
Flow Rate, Set Temp and Incoming Water Temp.

The tankless doesn't do anything when a faucet is opened.

The tankless shuts off after the water temp is adjusted.

The recirculation pump doesn't activate the unit.

Those are just a few examples of common complaints that you can start troubleshooting with MM14



38

MM30 INLET WATER TEMP

While this MM might not be as widely used as the others, it can still provide additional insight into why the heater is or is not doing something.

If the complaints are related to heater performance, such as not enough flow in the winter time or the heater doesn't activate in the summer time, you can use MM30 to establish the temperature rise and the BTU demand.

BTU Formula:

$$\text{BTU} = \text{Flow Rate in GPM} \times \text{Delta T} \times 500$$

Lets say the customers faucet flows .6 gpm, their set temp is 115 and the inlet water temp is 87. The Delta T is 28 (115 minus 87). Now let's put all those numbers into the formula:

$$.6 \times 28 \times 500 = \mathbf{8,400 \text{ BTU}}$$



39

MM31 OUTLET WATER TEMP

Along with MM14 (Flow Rate) this MM is one of the most used. This will tell you the temperature of the water leaving the unit. If you get any questions or complaints regarding hot water temperature this MM will be very useful.

- The water at the fixture doesn't feel hot enough.**
- The water temperature seems to fluctuate greatly.**
- The bathroom sink gets hot but the shower doesn't.**
- The unit has a 90 error code.**

The units goal is to get up to set temp as quickly as possible and maintain that temp as long as there is enough flow. Once the water leaves the unit, there are many things that can result in the water temp at the fixture being different. If the water temp leaving the unit is at set temp, the problem likely is with the plumbing or the fixtures.



40

MM32 HEAT EXCHANGER WATER TEMP

This MM is very helpful to determine if the burner is heating up the water in the HEX properly. It is also useful in troubleshooting a 90 error code (along with MM31).

Let's say you have a call for EC90 and you have determined it's because the unit is not hitting set temp. Why is the outlet temp low? Let's find out.

If MM32 shows 140, but MM31 shows 100 it would indicate there is a problem with the bypass servo (failed, stuck or debris in it).

If MM32 is also low, say 105 or 110 and MM31 shows 100 it would indicate the burner is not heating up the HEX high enough. Most likely not enough gas is entering the burner.

Both above examples would lead you down two very different troubleshooting paths so that's why checking MM32 is important when diagnosing low outlet temps.



41

MM86 RECIRCULATION MODE

This MM is specific to the NRCR Series. It will tell the recirculation mode the unit is set to. This is helpful to verify that the recirc mode is *actually* set the way you think it is.

MM 86	Recirculation Mode	Dedicated Mode	Crossover Mode
	Auto Recirc (Default)	11	21
	Manual Timer Recirc	12	22
	Recirc Always ON	13	23
	Recirc Always OFF	14	24
	On-Demand (Title 24)	15	25



42

1/2" GAS LINE DETAILS

Under certain specific conditions, a 1/2" gas line can be used. The length is equivalent length and factors in fittings and elbows.

Table 1. For Less than 8" WC initial supply pressure
Maximum Natural Gas Delivery Capacity (0.5" Pressure Drop) [Schedule 40 Metallic Pipe]

Pipe Size	Length (including fittings)										
	10' (3m)	20' (6m)	30' (9m)	40' (12m)	50' (15m)	60' (18m)	70' (21m)	80' (24m)	90' (27m)	100' (30m)	125' (38m)
3/4"	360	247	199	170	151	137	126	117	110	104	92
1"	678	466	374	320	284	257	237	220	207	195	173
1 1/4"	1,390										
1 1/2"	2,090	1,									
2"	4,020	2,									
2 1/2"	6,400	4,									
3"	11,300	7,									
4"	23,100	15,									

Table 2. For 8" WC – 10.5" WC initial supply pressure
Maximum Natural Gas Delivery Capacity (3.0" Pressure Drop) [Schedule 40 Metallic Pipe]

Pipe Size	Length (including fittings)										
	10' (3m)	20' (6m)	30' (9m)	40' (12m)	50' (15m)	60' (18m)	70' (21m)	80' (24m)	90' (27m)	100' (30m)	125' (38m)
1/2"	454	312	250	214	190	172	158	147	138	131	116
3/4"	949	652	524	448	397	360	331	308	289	273	242
1"	1,787	1,228	986	844	748	678	624	580	544	514	456
1 1/4"	3,669	2,522	2,025	1,733	1,536	1,392	1,280	1,191	1,118	1,056	936
1 1/2"	5,497	3,778	3,034	2,597	2,302	2,085	1,919	1,785	1,675	1,582	1,402
2"	10,588	7,277	5,844	5,001	4,433	4,016	3,695	3,437	3,225	3,046	2,700
2 1/2"	16,875	11,598	9,314	7,971	7,065	6,401	5,889	5,479	5,140	4,856	4,303
3"	29,832	20,503	16,465	14,092	12,489	11,316	10,411	9,685	9,087	8,584	7,608
4"	43,678	30,020	24,107	20,632	18,286	16,569	15,243	14,181	13,305	12,568	11,139



43

COMPONENT IDENTIFICATION

Circuit Board Gas System

- Gas Valve
- Venturi
- Fan Motor

Ignition System

- Igniter
- Ignition Rod

Heat Exchanger Assembly



44

PARTS LIST

Helpful to locate parts and what they connect to.

Hot-water feed route | EZ111DV (GQ-C3260WX-FF US)
EZ98DV (GQ-C2860WX-FF US)
UT199DV (GQ-C3260WX-FF PB US)

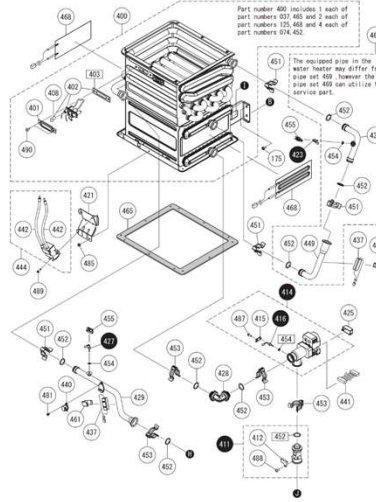

Hot-water feed route | EZ111DV (GQ-C3260WX-FF US)
EZ98DV (GQ-C2860WX-FF US)
UT199DV (GQ-C3260WX-FF PB US)

Part No.	Part Name	Order No.	Q'ty (unit)
400	Heat Exchanger Kit (SET)	702189	1
401	Mounting Plate - Ignition Plug	734945	1
402	Ignition Plug w. Shield	507281	1
403	Shield - Ignition Plug (HEX)	734939	1
404	Pressure Sensor	734940	1
405	Water Flow Sensor (SET)	100201	1
412	Pressure Sensor	248019	1
413	Water Servo - Bypass (SET)	510045	1
414	Water Servo - Main (SET)	510011	1
415	Pressure Switch (Main)	410080	1
416	Thermostat - Red	126027	1
417	Lead Water Connection (SET)	510046	1
418	Water Filler Cap	100202	1
419	Water Filter	100203	1
420	Pressure Switch (SET)	510047	1
421	Mounting Plate - Ignitor	734935	1
422	Thermostat - Blue	126021	1
423	Water Servo - Servo	510022	1
424	Water Connection - T-Elbow	734937	1
425	Water Connection - T-Elbow	734938	1
426	Water Connection - T-Elbow	734939	1
427	Pipe - Primary SS HEX to T-Elbow	734941	1
428	Pipe - Secondary SS HEX to Primary SS HEX	734942	1
429	Pipe - T-Elbow SS (Output Water Connection)	734943	1
430	Water Servo	510023	1
431	O-Ring - High Temp PS	100204	2
432	O-Ring - Elbow to Water Flow Sensor	734944	2
433	Flange Protection Water - Rectangular	510024	4
434	Flange Protection Water - Round (Set)	510025	1
435	Water Servo - Bypass Motor Servo	510027	1
440	High Limit Switch - 194	510028	1
441	Water Servo - Main Water Servo	510029	1
442	High Voltage Ignitor Wire L175	410078	2
443	Ignitor (SET)	510030	1
444	Pipe - Secondary SS HEX to Primary SS HEX	734945	1
445	Pipe Connection - 1/4" (Set)	510031	1
446	O-Ring - High Temp PS	100205	12
447	O-Ring - High Temp PS	100206	12
448	O-Ring - High Temp PS	100207	12
449	O-Ring - High Temp PS	100208	12
450	O-Ring - High Temp PS	100209	12
451	O-Ring - High Temp PS	100210	12
452	O-Ring - High Temp PS	100211	12
453	O-Ring - High Temp PS	100212	12
454	O-Ring - High Temp PS	100213	12
455	O-Ring - High Temp PS	100214	12
456	O-Ring - High Temp PS	100215	12
457	O-Ring - High Temp PS	100216	12
458	O-Ring - High Temp PS	100217	12
459	O-Ring - High Temp PS	100218	12
460	O-Ring - High Temp PS	100219	12
461	O-Ring - High Temp PS	100220	12
462	O-Ring - High Temp PS	100221	12
463	O-Ring - High Temp PS	100222	12
464	O-Ring - High Temp PS	100223	12
465	O-Ring - High Temp PS	100224	12
466	O-Ring - High Temp PS	100225	12
467	O-Ring - High Temp PS	100226	12
468	O-Ring - High Temp PS	100227	12
469	O-Ring - High Temp PS	100228	12
470	O-Ring - High Temp PS	100229	12
471	O-Ring - High Temp PS	100230	12
472	O-Ring - High Temp PS	100231	12
473	O-Ring - High Temp PS	100232	12
474	O-Ring - High Temp PS	100233	12
475	O-Ring - High Temp PS	100234	12
476	O-Ring - High Temp PS	100235	12
477	O-Ring - High Temp PS	100236	12
478	O-Ring - High Temp PS	100237	12
479	O-Ring - High Temp PS	100238	12
480	O-Ring - High Temp PS	100239	12
481	O-Ring - High Temp PS	100240	12
482	O-Ring - High Temp PS	100241	12
483	O-Ring - High Temp PS	100242	12
484	O-Ring - High Temp PS	100243	12
485	O-Ring - High Temp PS	100244	12
486	O-Ring - High Temp PS	100245	12
487	O-Ring - High Temp PS	100246	12
488	O-Ring - High Temp PS	100247	12
489	O-Ring - High Temp PS	100248	12
490	O-Ring - High Temp PS	100249	12
491	O-Ring - High Temp PS	100250	12
492	O-Ring - High Temp PS	100251	12
493	O-Ring - High Temp PS	100252	12
494	O-Ring - High Temp PS	100253	12
495	O-Ring - High Temp PS	100254	12
496	O-Ring - High Temp PS	100255	12
497	O-Ring - High Temp PS	100256	12
498	O-Ring - High Temp PS	100257	12
499	O-Ring - High Temp PS	100258	12
500	O-Ring - High Temp PS	100259	12
501	O-Ring - High Temp PS	100260	12
502	O-Ring - High Temp PS	100261	12
503	O-Ring - High Temp PS	100262	12
504	O-Ring - High Temp PS	100263	12
505	O-Ring - High Temp PS	100264	12
506	O-Ring - High Temp PS	100265	12
507	O-Ring - High Temp PS	100266	12
508	O-Ring - High Temp PS	100267	12
509	O-Ring - High Temp PS	100268	12
510	O-Ring - High Temp PS	100269	12
511	O-Ring - High Temp PS	100270	12
512	O-Ring - High Temp PS	100271	12
513	O-Ring - High Temp PS	100272	12
514	O-Ring - High Temp PS	100273	12
515	O-Ring - High Temp PS	100274	12
516	O-Ring - High Temp PS	100275	12
517	O-Ring - High Temp PS	100276	12
518	O-Ring - High Temp PS	100277	12
519	O-Ring - High Temp PS	100278	12
520	O-Ring - High Temp PS	100279	12
521	O-Ring - High Temp PS	100280	12
522	O-Ring - High Temp PS	100281	12
523	O-Ring - High Temp PS	100282	12
524	O-Ring - High Temp PS	100283	12
525	O-Ring - High Temp PS	100284	12
526	O-Ring - High Temp PS	100285	12
527	O-Ring - High Temp PS	100286	12
528	O-Ring - High Temp PS	100287	12
529	O-Ring - High Temp PS	100288	12
530	O-Ring - High Temp PS	100289	12
531	O-Ring - High Temp PS	100290	12
532	O-Ring - High Temp PS	100291	12
533	O-Ring - High Temp PS	100292	12
534	O-Ring - High Temp PS	100293	12
535	O-Ring - High Temp PS	100294	12
536	O-Ring - High Temp PS	100295	12
537	O-Ring - High Temp PS	100296	12
538	O-Ring - High Temp PS	100297	12
539	O-Ring - High Temp PS	100298	12
540	O-Ring - High Temp PS	100299	12
541	O-Ring - High Temp PS	100300	12
542	O-Ring - High Temp PS	100301	12
543	O-Ring - High Temp PS	100302	12
544	O-Ring - High Temp PS	100303	12
545	O-Ring - High Temp PS	100304	12
546	O-Ring - High Temp PS	100305	12
547	O-Ring - High Temp PS	100306	12
548	O-Ring - High Temp PS	100307	12
549	O-Ring - High Temp PS	100308	12
550	O-Ring - High Temp PS	100309	12
551	O-Ring - High Temp PS	100310	12
552	O-Ring - High Temp PS	100311	12
553	O-Ring - High Temp PS	100312	12
554	O-Ring - High Temp PS	100313	12
555	O-Ring - High Temp PS	100314	12
556	O-Ring - High Temp PS	100315	12
557	O-Ring - High Temp PS	100316	12
558	O-Ring - High Temp PS	100317	12
559	O-Ring - High Temp PS	100318	12
560	O-Ring - High Temp PS	100319	12
561	O-Ring - High Temp PS	100320	12
562	O-Ring - High Temp PS	100321	12
563	O-Ring - High Temp PS	100322	12
564	O-Ring - High Temp PS	100323	12
565	O-Ring - High Temp PS	100324	12
566	O-Ring - High Temp PS	100325	12
567	O-Ring - High Temp PS	100326	12
568	O-Ring - High Temp PS	100327	12
569	O-Ring - High Temp PS	100328	12
570	O-Ring - High Temp PS	100329	12
571	O-Ring - High Temp PS	100330	12
572	O-Ring - High Temp PS	100331	12
573	O-Ring - High Temp PS	100332	12
574	O-Ring - High Temp PS	100333	12
575	O-Ring - High Temp PS	100334	12
576	O-Ring - High Temp PS	100335	12
577	O-Ring - High Temp PS	100336	12
578	O-Ring - High Temp PS	100337	12
579	O-Ring - High Temp PS	100338	12
580	O-Ring - High Temp PS	100339	12
581	O-Ring - High Temp PS	100340	12
582	O-Ring - High Temp PS	100341	12
583	O-Ring - High Temp PS	100342	12
584	O-Ring - High Temp PS	100343	12
585	O-Ring - High Temp PS	100344	12
586	O-Ring - High Temp PS	100345	12
587	O-Ring - High Temp PS	100346	12
588	O-Ring - High Temp PS	100347	12
589	O-Ring - High Temp PS	100348	12
590	O-Ring - High Temp PS	100349	12
591	O-Ring - High Temp PS	100350	12
592	O-Ring - High Temp PS	100351	12
593	O-Ring - High Temp PS	100352	12
594	O-Ring - High Temp PS	100353	12
595	O-Ring - High Temp PS	100354	12
596	O-Ring - High Temp PS	100355	12
597	O-Ring - High Temp PS	100356	12
598	O-Ring - High Temp PS	100357	12
599	O-Ring - High Temp PS	100358	12
600	O-Ring - High Temp PS	100359	12
601	O-Ring - High Temp PS	100360	12
602	O-Ring - High Temp PS	100361	12
603	O-Ring - High Temp PS	100362	12
604	O-Ring - High Temp PS	100363	12
605	O-Ring - High Temp PS	100364	12
606	O-Ring - High Temp PS	100365	12
607	O-Ring - High Temp PS	100366	12
608	O-Ring - High Temp PS	100367	12
609	O-Ring - High Temp PS	100368	12
610	O-Ring - High Temp PS	100369	12
611	O-Ring - High Temp PS	100370	12
612	O-Ring - High Temp PS	100371	12
613	O-Ring - High Temp PS	100372	12
614	O-Ring - High Temp PS	100373	12
615	O-Ring - High Temp PS	100374	12
616	O-Ring - High Temp PS	100375	12
617	O-Ring - High Temp PS	100376	12
618	O-Ring - High Temp PS	100377	12
619	O-Ring - High Temp PS	100378	12
620	O-Ring - High Temp PS	100379	12
621	O-Ring - High Temp PS	100380	12
622	O-Ring - High Temp PS	100381	12
623	O-Ring - High Temp PS	100382	12
624	O-Ring - High Temp PS	100383	12
625	O-Ring - High Temp PS	100384	12
626	O-Ring - High Temp PS	100385	12
627	O-Ring - High Temp PS	100386	12
628	O-Ring - High Temp PS	100387	12
629	O-Ring - High Temp PS	100388	12
630	O-Ring - High Temp PS	100389	12
631	O-Ring - High Temp PS	100390	12
632	O-Ring - High Temp PS	100391	12
633	O-Ring - High Temp PS	100392	12
634	O-Ring - High Temp PS	100393	12
635	O-Ring - High Temp PS	100394	12
636	O-Ring - High Temp PS	100395	12
637	O-Ring - High Temp PS	100396	12
638	O-Ring - High Temp PS	100397	12
639	O-Ring - High Temp PS	100398	12
640	O-Ring - High Temp PS	100399	12
641	O-Ring - High Temp PS	100400	12
642	O-Ring - High Temp PS	100401	12
643	O-Ring - High Temp PS	100402	12
644	O-Ring - High Temp PS	100403	12
645	O-Ring - High Temp PS	100404	12
646	O-Ring - High Temp PS	100405	12
647	O-Ring - High Temp PS	100406	12
648	O-Ring - High Temp PS	100407	12
649	O-Ring - High Temp PS	100408	12
650	O-Ring - High Temp PS	100409	12
651	O-Ring - High Temp PS	100410	12
652	O-Ring - High Temp PS	100411	12
653	O-Ring - High Temp PS	100412	12
654	O-Ring - High Temp PS	100413	12
655	O-Ring - High Temp PS	100414	12
656	O-Ring - High Temp PS	100415	12
657	O-Ring - High Temp PS	100416	12
658	O-Ring - High Temp PS	100417	12
659	O-Ring - High Temp PS	100418	12
660	O-Ring - High Temp PS	100419	12
661	O-Ring - High Temp PS	100420	12
662	O-Ring - High Temp PS	100421	12
663	O-Ring - High Temp PS	100422	12
664	O-Ring - High Temp PS	100423	12
665	O-Ring - High Temp PS	100424	12
666	O-Ring - High Temp PS	100425	12
667	O-Ring - High Temp PS	100426	12
668	O-Ring - High Temp PS	100427	12
669	O-Ring - High Temp PS	100428	12
670	O-Ring - High Temp PS	100429	12
671	O-Ring - High Temp PS	100430	12
672	O-Ring - High Temp PS	100431	12
673	O-Ring - High Temp PS	100432	12
674	O-Ring - High Temp PS	100433	12
675	O-Ring - High Temp PS	100434	12
676	O-Ring - High Temp PS	100435	12
677	O-Ring - High Temp PS	100436	12
678	O-Ring - High Temp PS	100437	12
679	O-Ring - High Temp PS	100438	12
680	O-Ring - High Temp PS	100439	12
681	O-Ring - High Temp PS	100440	12
682	O-Ring - High Temp PS	100441	12
683	O-Ring - High Temp PS	100442	12
684	O-Ring - High Temp PS	100443	12
685	O-Ring - High Temp PS	100444	12
686	O-Ring - High Temp PS	100445	12
687	O-Ring - High Temp PS	100446	12
688	O-Ring - High Temp PS	100447	12
689	O-Ring - High Temp PS	100448	12
690	O-Ring - High Temp PS	100449	12
691	O-Ring - High Temp PS	100450	12

CIRCUIT BOARD

Control center of the unit.

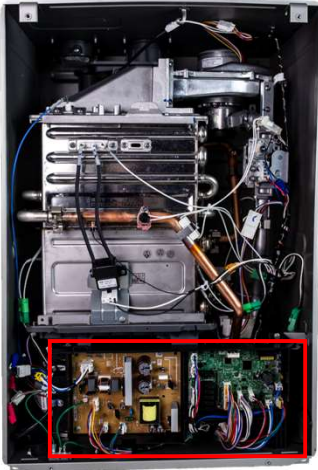

47

GAS VALVE

Pre-mix units have a negative pressure gas system. DC voltage opens the main gas solenoid and the negative pressure created by the fan draws gas out of the valve and into the venturi.

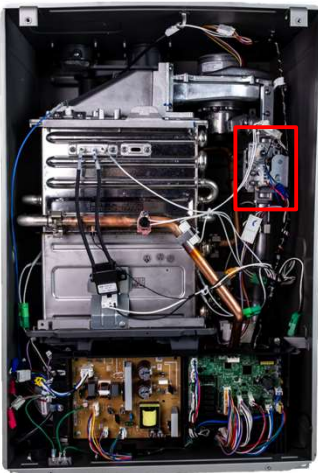

48

VENTURI

This is specific to the Pre-Mix type units. Air and Gas are introduced here and then enter the Fan Housing to be mixed before entering the Burner



49

FAN MOTOR

In Pre-Mix units, the fan acts as a blender and mixes the air and gas together before pushing it into the burner.

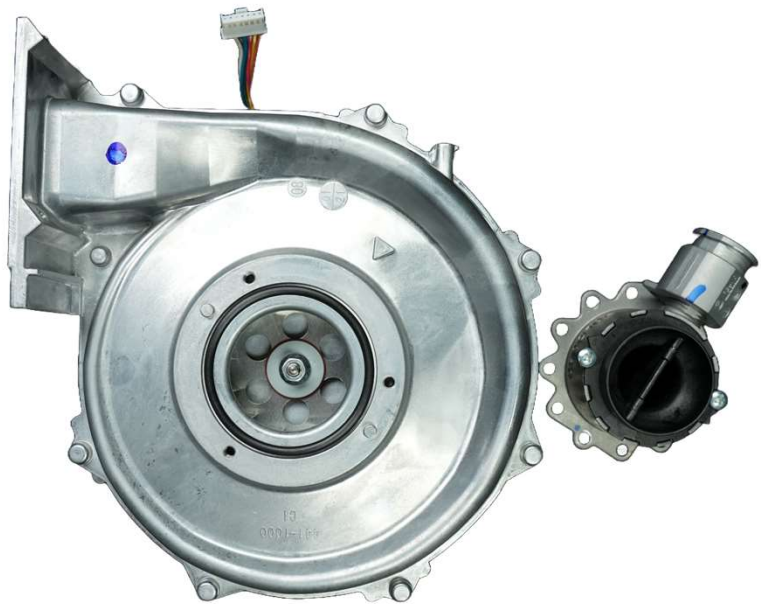
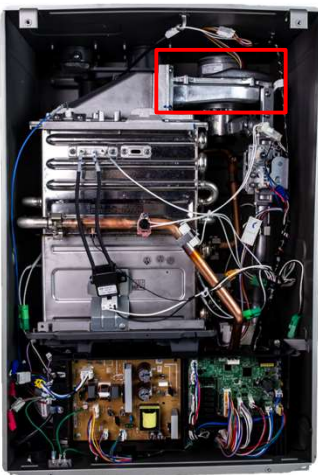

50

IGNITION SYSTEM

Igniter and Ignition Rods. Responsible for creating spark to ignite the air/fuel mixture.

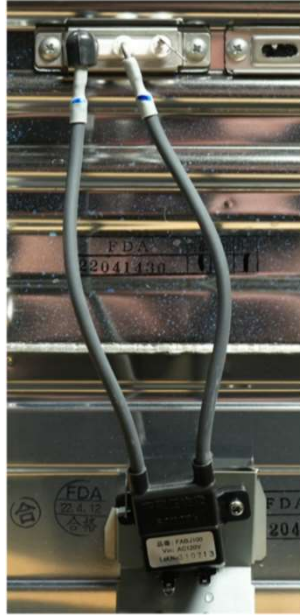
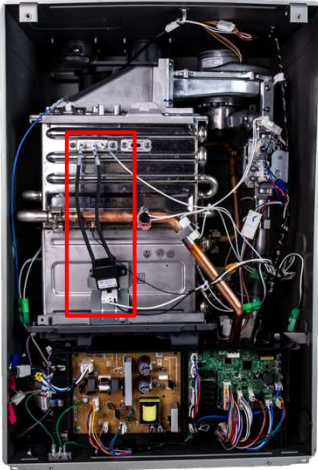

 NORITZ®

51

HEAT EXCHANGER ASSEMBLY

Transfers heat from the burner and exhaust into the water.

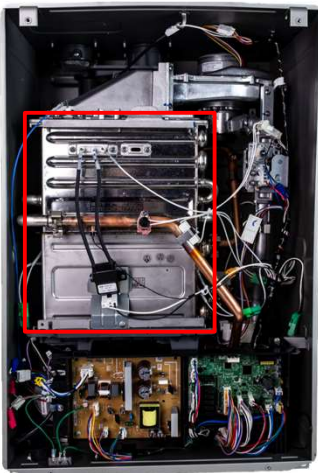

 NORITZ®

52

PROCARD APP

ANDROID



APPLE



The PROCard App (available for both iOS and Android) is a great tool to have on your phone!

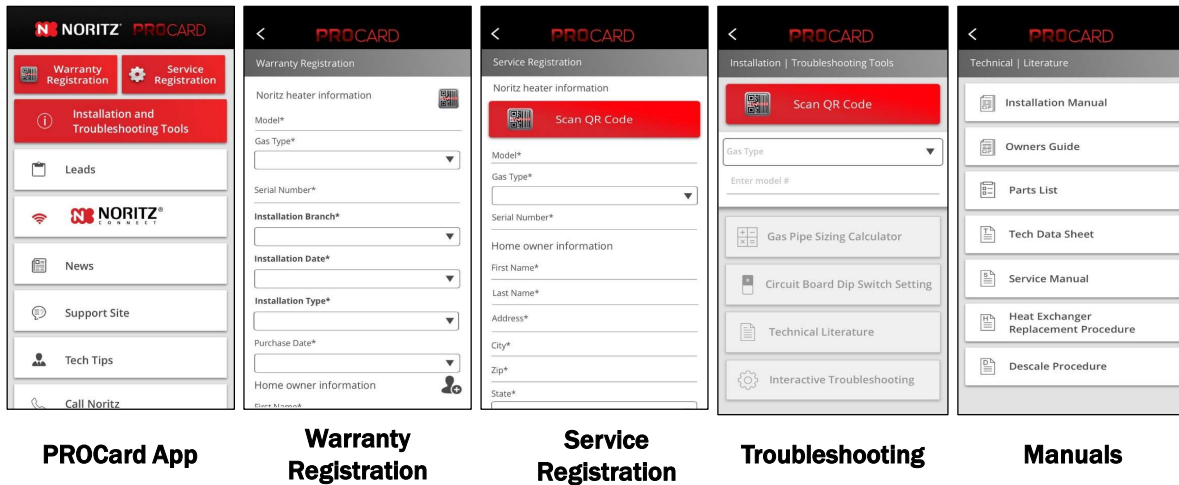

53

CONTACTING CUSTOMER CARE

866-766-7489

(866) - 7NORITZ

Please have readily available:

- Model Number
- Serial Number

Being onsite with the unit is not mandatory, but very helpful!

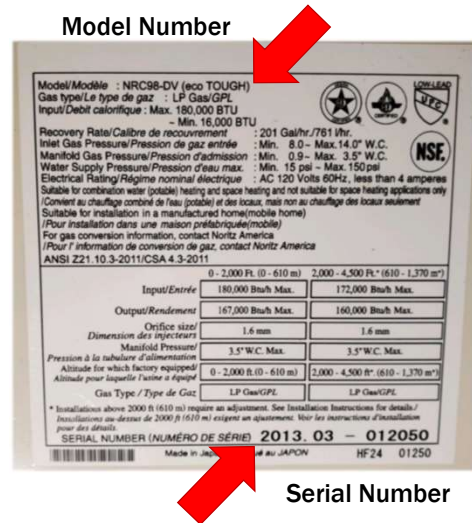

54

HELPFUL LINKS

866-7NORITZ (866-766-7489)



EZ Start Plus App
(For New Pro Units)



Gas Conversion
(For New Pro Units)



SUPPORT.NORITZ.COM



NORITZ.COM/TECHTIPS



HELP.NORITZ.COM



TRAINING.NORITZ.COM



 YOUTUBE.COM/
NORITZAMERICA



PROCARD.NORITZ.COM



55

THANK YOU



56