

NORITZ[®] RESIDENTIAL LEVEL 1

Product Line, Accessories
and Installation Basics



1

READ THE MANUAL

Tankless units are combustion appliances that contain gas, water and electricity in a unit the size of a suitcase.

The proper, safe and reliable operation of our units is 100% contingent on a correct installation and proper maintenance throughout its life.

7 Connecting the Gas Supply

Follow the instructions from the gas supplier.

WARNING

The piping and installation of the gas system for the tankless water heater is an unlicensed activity. It is the responsibility of the installer to ensure that all work is done in accordance with all applicable codes and regulations.

Gas Type

The gas type indicated on the Water Heater's rating label must be installed in the gas piping system.

Gas Connections

- If the existing gas piping meets the gas type on the rating label, install the water heater on the existing gas piping.
- If a gas conversion is needed, there are several options available for conversion. Consult the manufacturer's literature for all applicable codes and regulations of the authority having jurisdiction. The authority having jurisdiction may require the installation of a gas shut-off valve on the gas piping to the water heater.

Notes

- The gas meter must be sized properly for the water heater and other gas appliances in the area.
- The gas meter must be installed in an accessible location.
- The gas meter must be installed in a location that is not subject to flooding.

Precautions

- Do not install the gas piping until the water heater is properly vented.
- Do not install the gas piping until the water heater is properly vented.

WARNING

Do not install the gas piping until the water heater is properly vented.

Notes

- Check the gas supply pressure immediately before and after installation.
- Tighten gas pressure must be within the limits.

8 Connecting the Water Supply

Consult a plumber for the water supply.

The water supply must be installed in the water heater's water supply inlet.

The water supply must be installed in the water heater's water supply inlet.

The water supply must be installed in the water heater's water supply inlet.

The water supply must be installed in the water heater's water supply inlet.

The water supply must be installed in the water heater's water supply inlet.

The water supply must be installed in the water heater's water supply inlet.

The water supply must be installed in the water heater's water supply inlet.

The water supply must be installed in the water heater's water supply inlet.

The water supply must be installed in the water heater's water supply inlet.

The water supply must be installed in the water heater's water supply inlet.

The water supply must be installed in the water heater's water supply inlet.

The water supply must be installed in the water heater's water supply inlet.

The water supply must be installed in the water heater's water supply inlet.

The water supply must be installed in the water heater's water supply inlet.

The water supply must be installed in the water heater's water supply inlet.

The water supply must be installed in the water heater's water supply inlet.

The water supply must be installed in the water heater's water supply inlet.

The water supply must be installed in the water heater's water supply inlet.

The water supply must be installed in the water heater's water supply inlet.

The water supply must be installed in the water heater's water supply inlet.

The water supply must be installed in the water heater's water supply inlet.

The water supply must be installed in the water heater's water supply inlet.

The water supply must be installed in the water heater's water supply inlet.

The water supply must be installed in the water heater's water supply inlet.

The water supply must be installed in the water heater's water supply inlet.

The water supply must be installed in the water heater's water supply inlet.

The water supply must be installed in the water heater's water supply inlet.

The water supply must be installed in the water heater's water supply inlet.

The water supply must be installed in the water heater's water supply inlet.

The water supply must be installed in the water heater's water supply inlet.

The water supply must be installed in the water heater's water supply inlet.

The water supply must be installed in the water heater's water supply inlet.

The water supply must be installed in the water heater's water supply inlet.

The water supply must be installed in the water heater's water supply inlet.

The water supply must be installed in the water heater's water supply inlet.

Precautions

The water supply must be installed in the water heater's water supply inlet.

The water supply must be installed in the water heater's water supply inlet.

The water supply must be installed in the water heater's water supply inlet.

The water supply must be installed in the water heater's water supply inlet.

The water supply must be installed in the water heater's water supply inlet.

The water supply must be installed in the water heater's water supply inlet.

The water supply must be installed in the water heater's water supply inlet.

The water supply must be installed in the water heater's water supply inlet.

The water supply must be installed in the water heater's water supply inlet.

The water supply must be installed in the water heater's water supply inlet.

The water supply must be installed in the water heater's water supply inlet.

The water supply must be installed in the water heater's water supply inlet.

The water supply must be installed in the water heater's water supply inlet.

The water supply must be installed in the water heater's water supply inlet.

The water supply must be installed in the water heater's water supply inlet.

The water supply must be installed in the water heater's water supply inlet.

The water supply must be installed in the water heater's water supply inlet.

The water supply must be installed in the water heater's water supply inlet.

The water supply must be installed in the water heater's water supply inlet.

The water supply must be installed in the water heater's water supply inlet.

The water supply must be installed in the water heater's water supply inlet.

The water supply must be installed in the water heater's water supply inlet.

The water supply must be installed in the water heater's water supply inlet.

The water supply must be installed in the water heater's water supply inlet.

The water supply must be installed in the water heater's water supply inlet.

The water supply must be installed in the water heater's water supply inlet.

The water supply must be installed in the water heater's water supply inlet.

The water supply must be installed in the water heater's water supply inlet.

The water supply must be installed in the water heater's water supply inlet.

The water supply must be installed in the water heater's water supply inlet.

The water supply must be installed in the water heater's water supply inlet.

The water supply must be installed in the water heater's water supply inlet.

The water supply must be installed in the water heater's water supply inlet.

The water supply must be installed in the water heater's water supply inlet.

The water supply must be installed in the water heater's water supply inlet.



Low NOx Approved by SCAQMD
14 ng/l or 20 ppm
(Natural Gas Only)

2

TRAINING SECTIONS



NORITZ

Residential Product Line:

- Standard Efficiency
- High Efficiency
- Pre-mix Units
- EZTR Packages

Installation:

- Unit Sizing
- Gas Line
- Choosing Location
- Venting
- Condensate Line
- EZ Start Plus App
- Circuit Board Dipswitches
- Install Checklist

Maintenance:

- Water Quality
- Water Treatment
- Cleaning Unit

3

WHAT IS A TANKLESS WATER HEATER?

A tankless water heater uses a burner and heat exchanger to produce an endless supply of hot water on-demand.

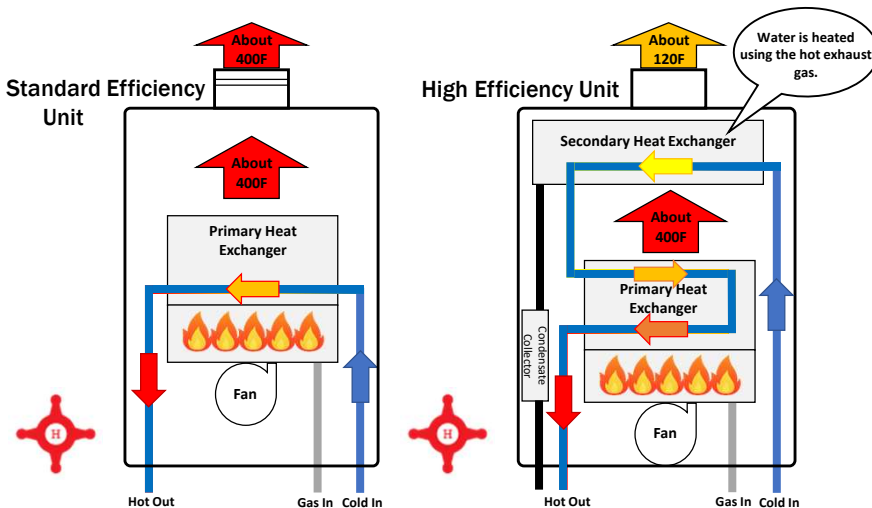

Tankless Operation:

- 1) Hot water fixture is opened
- 2) Tankless detects flow
- 3) Burner ignites
- 4) Water is heated in the Heat Exchanger
- 5) Hot water exits the tankless to the fixture
- 6) Fixture is closed and tankless shuts off

NORITZ

4

STANDARD EFFICIENCY UNITS



NR98SV
Max 199k btu

- Non-Condensing Units
- 120k to 199k btu
- UEF = 0.82
- Indoor and Outdoor Units Available (7 units total)
- Indoor Units Require Cat III Stainless Steel Venting
- All Units Satisfy 20ppm Low NOx Requirements
- Copper Heat Exchanger
- 12 Years Heat Exchanger
- 5 Years All Other Parts
- 1 Year Reasonable Labor



5

HIGH EFFICIENCY UNITS



NRC98DV
Max 180k btu

- Condensing Units
- 120k to 199k btu
- UEF = 0.87 to 0.92 (depending on the unit)
- Indoor and Outdoor Units Available (8 units total)
- Indoor Units Use 3" or 4" PVC/CPVC/PP
- All Units Satisfy 20ppm Low NOx Requirements
- Copper Primary Heat Exchanger
- Stainless Steel Secondary Heat Exchanger
- 12 Years Heat Exchanger
- 5 Years All Other Parts
- 1 Year Reasonable Labor



6

STANDARD & HIGH EFFICIENCY UNITS



NRC98DV
Max 180k btu



NR98SV
Max 199k btu

All units include either an external remote control or built in display window for easy indication of set temperature along with monitoring and diagnostics capability.



NRC661DV
Max 120k btu



NR660D
Max 120k btu



7

HIGH EFFICIENCY PRE-MIX UNITS

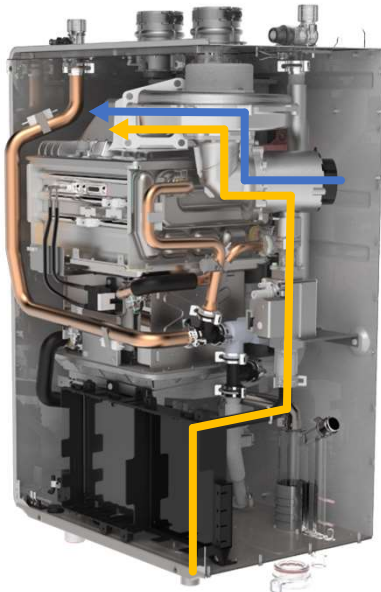

Pre-Mix refers to how the air and gas is pre-mixed in the fan before entering the burner

Pre-Mix units have Dual Stainless Steel Heat Exchangers

The Noritz Pre-mix Lineup:

- EZ PRO Series
- NRCR PRO Series
- NRCB Boiler
- NCC199CDV PRO (commercial unit)



8

EZ SERIES PRO OVERVIEW



Available Models:

EZ71DV: 12,800 – 160,000 BTUh / 0.4 - 9.0 gpm

EZ98DV: 12,800 – 180,000 BTUh / 0.4 - 9.8 gpm

EZ111DV: 12,800 – 199,900 BTUh / 0.4 - 11.1 gpm

Key Features:

- Top Mounted Water Connections
- UEF = 0.98
- EZ Start Plus Bluetooth® App
- Built-in Operation Panel
- Field Gas Conversion (included in the box)
- Versatile Venting (one model for Indoor and Outdoor installations)
- 2", 3" or 4" PVC/CPVC/PP
 - 2" Max length: 75'
 - 3" Max length: 150'
 - 4" Max length: 65'
- Flexible 2" SV up to 35'
- 25 Year Heat Exchanger Warranty



9

EZ SERIES PRO GAS CONVERSION



Scan for
Conversion Video

All PRO Series models are ready for use with NG and include a simple field gas conversion to LP.

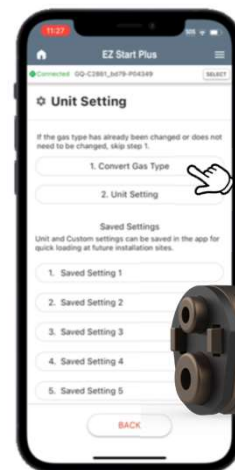

10

NRCR PRO OVERVIEW



Available Models:

NRCR92DV: 12,800 – 165,000 BTUh / 0.4 - 9.2 gpm

NRCR111DV: 12,800 – 199,900 BTUh / 0.4 – 11.1 gpm

Key Features:

- Built-In Recirculation Pump
- UEF = 0.98
- EZ Start Plus Bluetooth® App
- Versatile Venting (Just like EZ Pro Series)
- Steady BTU Control
- 15 Year Heat Exchanger Warranty

Recirc Setting:

- Auto Learning (Default)
- Manual Timer (Using EZ Start Plus Bluetooth app)
- Title 24 (On Demand)

Recirc Types:

- Dedicated Recirculation
- Crossover (up to 2)



11

NRCR PRO VENTING



The NRCR PRO is a pre-mix style unit and thus has the same venting options as the EZ PRO Series:

- DV Direct Vent
- SV Single Vent
- OD Outdoor
- No Roof Kit
- FSV Flexible Single Vent
- Common Vent Capable (2 Units Quick Connected)



12

NRCR **PRO** DEDICATED



Return Line should have a shut off valve, hose bibb and expansion tank

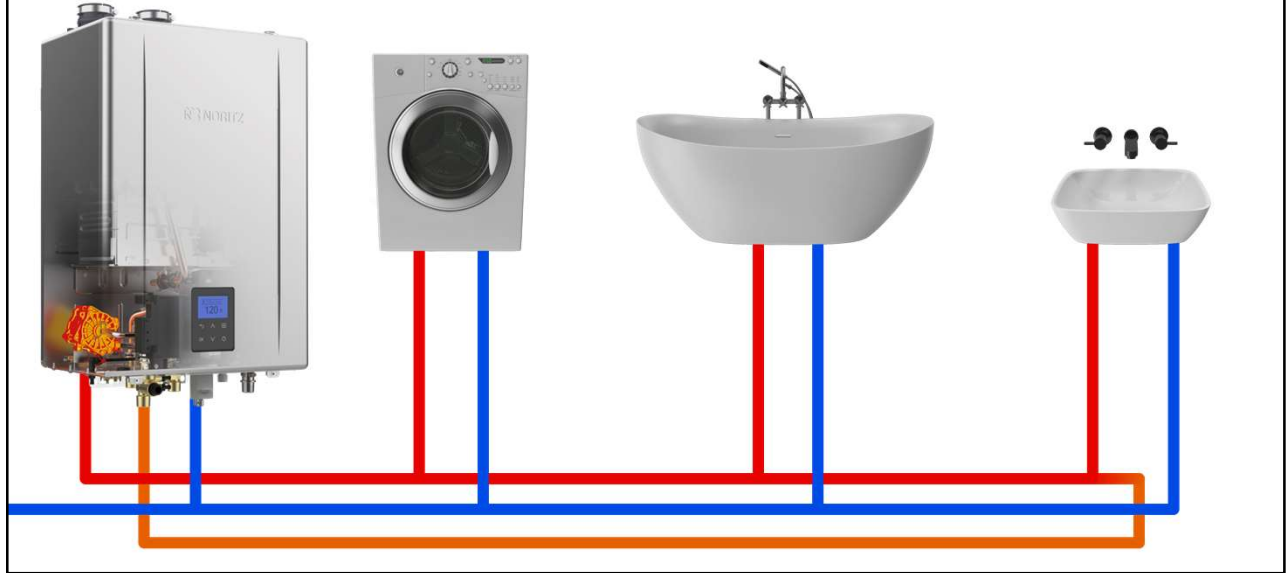

13

NRCR **PRO** CROSSOVER

When using a crossover valve, the minimum set temperature is 120 F



CROSSOVER KIT
CSV-87K

Our crossover kit brings recirculation to homes without a return line. Set your NRCR to crossover mode after installation and your home is ready for faster, hot water.

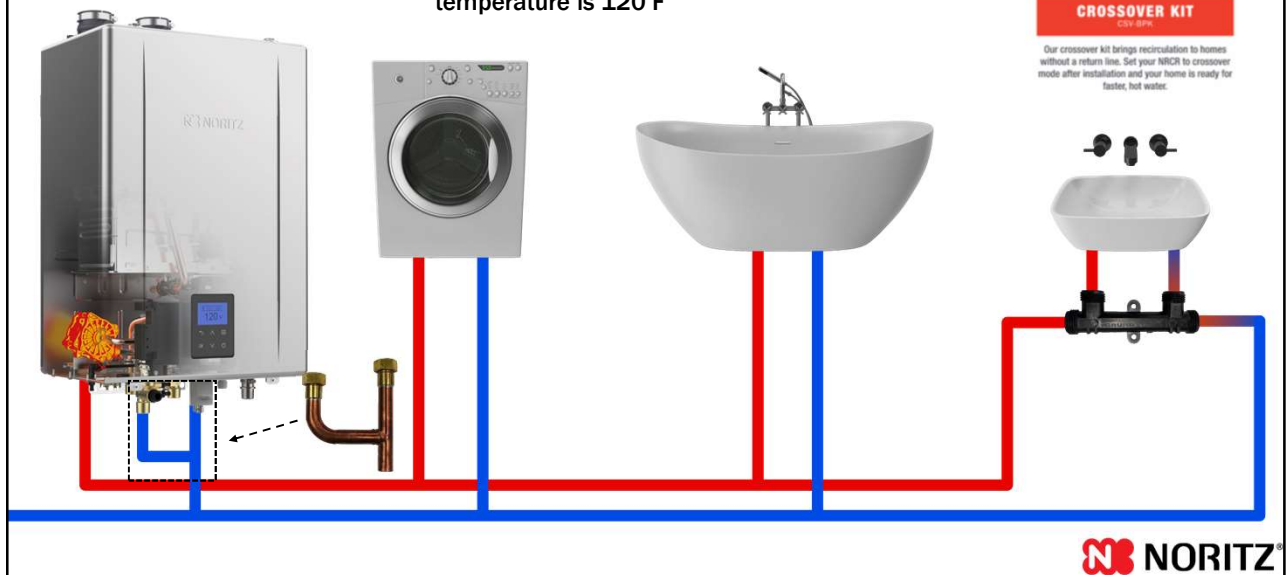

14

NRCR **PRO** 2 CROSSOVER

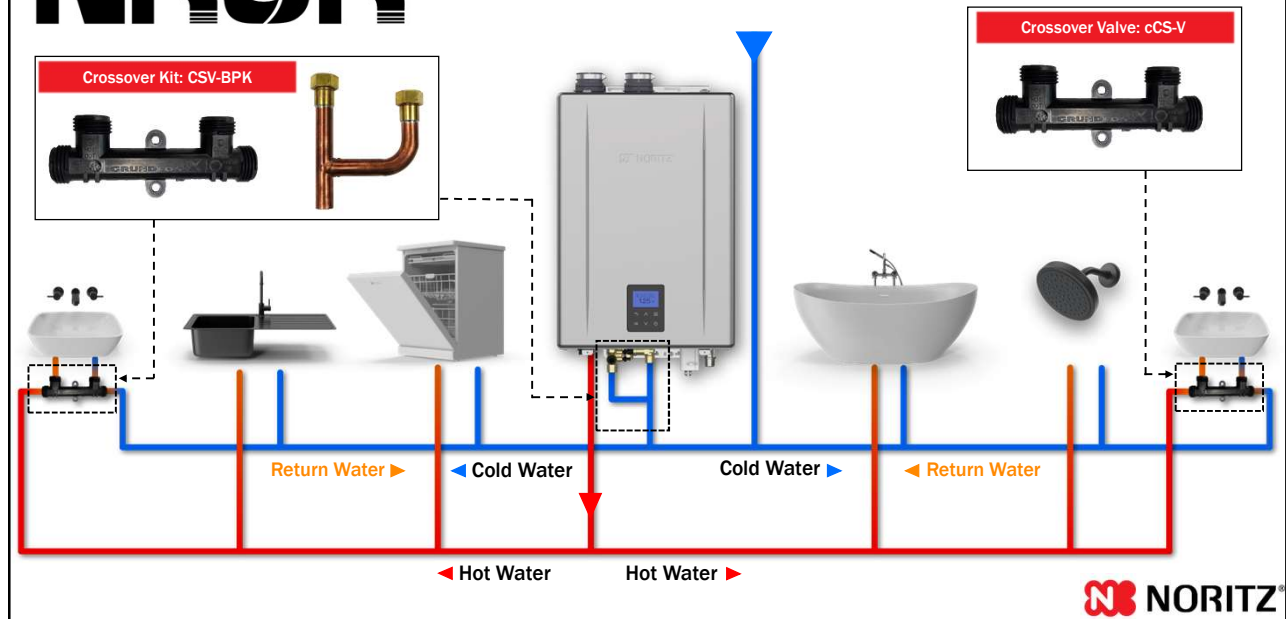

15

NRCR **PRO** AUTO LEARNING



Auto Learning mode memorizes the customers usage patterns and automatically runs the pump during the hours hot water is needed. If the customers patterns change, the unit will adapt and remove times when it appears the customer no longer uses hot water.

NORITZ

16

NRCR **PRO** MANUAL SCHEDULE



Schedule the NRCR PRO recirc times manually with the EZ Start Plus App. Simply tap the hours you want the pump to run.

Want the same schedule every weekday? Adjust the schedule for one day then copy to all weekdays.

No longer requires extra purchase!



17

NRCR **PRO** TITLE 24 ON DEMAND



On Demand mode only runs the pump when the customer presses a button or activates a motion sensor.



Wireless Push Button Kit (WLB)



Optional Motion Sensor (WLB-MS)



Rocker Switch (IHK-RS)



18

EZTR40 PACKAGE



- EZ Tank Replacement of a 40 Gallon Tank
- Bundle kits include Unit, Isolation Valves and 25' Flex Vent Kit (35' Optional, sold separately)
- Top Mounted Water Connections
- 120k Max btu High Efficiency Unit
- 6.6 gpm Max
- UEF = 0.87
- Copper Primary HEX and SS Secondary HEX
- 12 Year Heat Exchanger Warranty

The EZTR40 can *only* be used when replacing a tank and using the flexible venting, it *cannot* be adapted to vent with PVC or other rigid plastic venting.



19

EZTR50 & EZTR75 PACKAGES



- EZ Tank Replacement of a 50 or 75 Gallon Tank
- Bundle kits include Unit, Isolation Valves and 25' Flex Vent Kit (35' Optional, sold separately)
- Top Mounted Water Connections
- EZTR50 includes EZ98 PRO Unit (180k btu/9.8 gpm)
- EZTR75 includes EZ111 PRO Unit (199k btu/11.1 gpm)
- Dual Stainless Steel Heat Exchangers
- UEF = 0.98
- Built-in Operation Panel
- EZ Start Plus Bluetooth® App
- Field Gas Conversion
- 25 Year Heat Exchanger Warranty



20

EZTR PACKAGES

Use existing 3" or 4" round b-vent
(no oval vent or common venting with other appliance)

25' included with EZTR package.

35' vent kit optional, part # EZ2FVK-2

NOTE: Flexible vent can be shortened but you *cannot* join 2 pieces of flexible vent to extend the length.

Example: If you need 30', you would buy the 35' kit and cut off 5'. You would *not* attach an extra 5' to the included 25' kit.

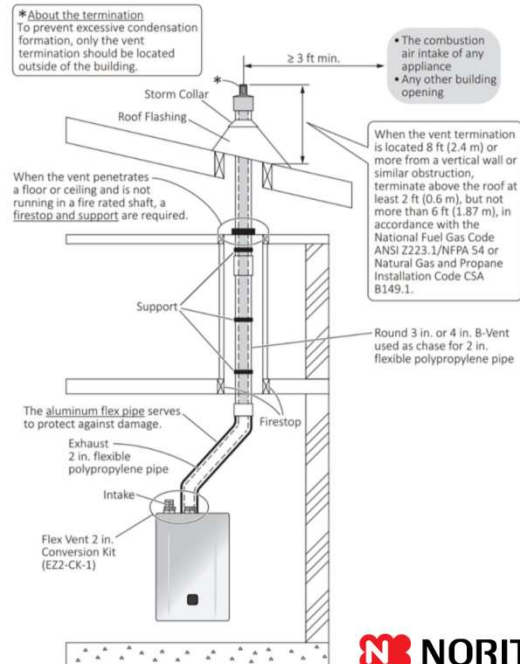

21

EXTERNAL RECIRCULATION



**RPK-EXT
Pump Kit**

Many Noritz units are compatible with external recirculation pumps such as the Noritz RPK-EXT pump kit.

Important Notes:

- Display Window Units are not compatible with the RPK-EXT pump kit as they do not have a pump control connection. An externally controlled pump may still be used though
- Single unit installations only (Will not work with Quick Connected Systems)
- Remote included with RPK-EXT kit is optional on EZ PRO and CDV PRO units that use the EZ Start Plus App



22

EXTERNAL RECIRCULATION

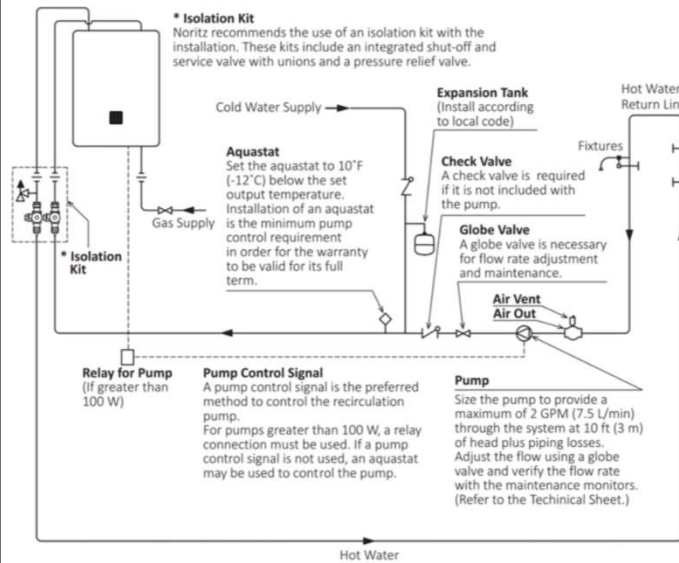

Typical Recirc Diagram

- Size pump for 2 gpm max flow
- Control pump with timer or aquastat or use pump connection wires inside unit
- Set aquastat 10 degrees below unit set temperature



23

HOW TO SIZE A TANKLESS

Proper sizing is a key aspect of the customers experience and satisfaction with their tankless.

An undersized tankless *will* provide the proper temperature but the customer will not be able to run as many hot water fixtures at the same time as they want.

This problem will be more apparent in the wintertime as the cold-water temperatures are even colder.



24

HOW TO SIZE A TANKLESS: STEP 1

Step 1: Determine your maximum temperature rise. This is the difference between the tankless set temp and the wintertime ground water temp (aka Delta T)

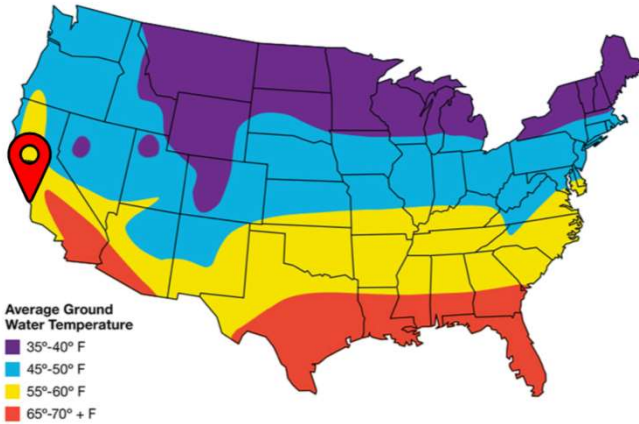

For the purpose of this example let's say the home is on the central coast of California.

Based on the map, we'll say the winter ground water temp is 55 F.

Now you can determine the wintertime temperature rise:

$$120 \text{ Set Temp} - 55 \text{ Ground Water Temp} = 65 \text{ Delta T}$$



25

HOW TO SIZE A TANKLESS: STEP 2

Step 2: Determine the peak hot water demand of the home. If possible, ask the homeowner.

Fixtures and appliances all have different flow rates depending on manufacturer however you can use an average amount to get a ballpark figure:

- Shower:** 2 gpm
- Lav Sink:** 1 gpm
- Kitchen Sink:** 1.5 gpm
- Dishwasher:** 2 gpm
- Washing Machine:** 2 gpm



Example 1:

Peak usage: 2 Showers & Washing Machine = 6 gpm

Example 2:

Peak usage: 4 Showers & Dishwasher = 10 gpm



26

HOW TO SIZE A TANKLESS: STEP 3



Step 3: Select the proper unit or pair of units using the sizing chart found online or in the product catalog.

Simply find the Temperature Rise on the left then match up a unit or pair of units that provides the approximate flow rate needed.

Temp Rise: 65

Example 1:

Peak usage: 2 Showers & Washing Machine = 6 gpm

Ideal Models:

EZ111, NRCR111 or NRC111

Example 2:

Peak usage: 4 Showers & Dish Washer = 10 gpm

Ideal Models:

Pair of EZ98, NRC98 or NRCR92

Temp Rise (F)	CONDENSING								
	EZ111 PRO	NRCR111 PRO	NRC111	EZ98 PRO	NRC98	NRCR92 PRO	EZ71 PRO	NRC711	NRC663 (EZTR40)
30	11.1	11.1	11.1	9.8	9.8	9.2	9.0	7.1	6.6
35	11.1	10.9	9.8	9.8	9.6	9.2	8.4	7.1	6.4
40	9.8	9.7	9.3	8.6	8.4	8.0	7.7	7.1	5.5
45	8.7	8.6	8.4	7.6	7.4	7.1	6.9	6.5	4.9
50	7.8	7.8	7.4	6.9	6.7	6.4	6.2	5.8	4.4
55	7.1	7.1	6.9	6.3	6.1	5.8	5.7	5.3	4.1
60	6.5	6.5	6.2	5.7	5.6	5.3	5.2	4.9	3.7
65	6.0	6.0	5.8	5.3	5.2	4.9	4.8	4.5	3.4
70	5.5	5.5	5.3	4.9	4.8	4.5	4.4	4.2	3.2
75	5.2	5.2	5.1	4.6	4.5	4.3	4.0	3.9	3.0
80	4.9	4.8	4.6	4.4	4.2	4.0	3.9	3.7	2.8
85	4.6	4.6	4.5	4.1	3.9	3.8	3.6	3.4	2.6
90	4.4	4.3	4.1	3.8	3.7	3.6	3.4	3.2	2.5
95	4.1	4.1	4.0	3.6	3.5	3.4	3.2	3.1	2.3
100	3.9	3.9	3.7	3.4	3.4	3.2	3.1	2.9	2.2

27

HOW TO SIZE A TANKLESS: FINAL TIP



Final Sizing Tip:



SCAN HERE FOR SIZING VIDEO

It's always better to slightly oversize a tankless system than to undersize it.

There's virtually no downside to an oversized system for the home however and undersized system will not provide enough hot water for the home during all times of the year.



28

QUICK CONNECT SYSTEMS

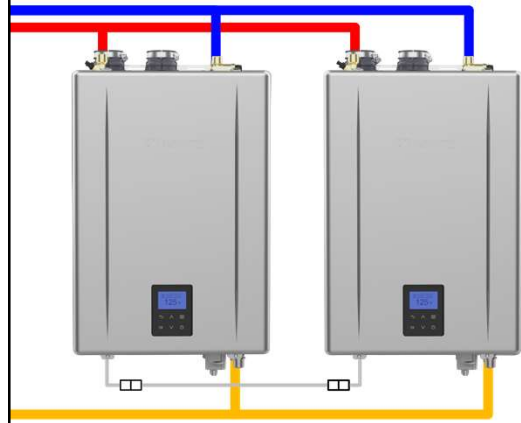

For large residential applications 2 compatible Noritz units may be quick connected to double the hot water output.



Part #: QC-2



29

QUICK CONNECT SYSTEMS

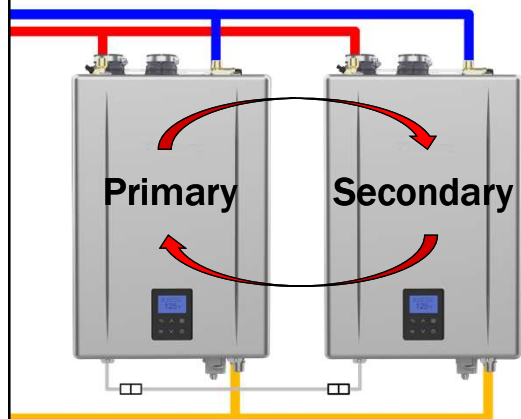

The system will automatically rotate primary and secondary roles to ensure even use of both units.



Part #: QC-2



30

QUICK CONNECT SYSTEMS

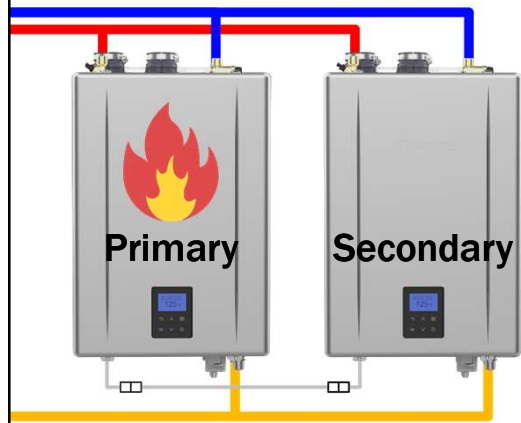

When there's a small demand, only the primary heater will fire up to meet the demand.



Part #: QC-2

 NORITZ®

31

QUICK CONNECT SYSTEMS

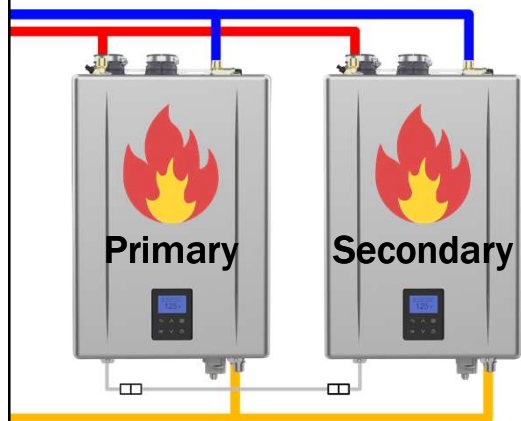

If the demand increases the primary unit will activate the secondary unit to help meet the demand.



Part #: QC-2

 NORITZ®

32

QUICK CONNECT SYSTEMS

Only the PRO Series and larger residential units with an external remote are compatible with the quick connect cable, smaller display window units are designed for single unit installations.



33

GAS LINE SIZING

Of equal importance to a proper sized unit, is a properly sized and installed gas line to ensure adequate gas pressure.

Afterall, what good is selecting the perfect tankless if the gas system can't support it's needs?

Required Gas Supply Pressure

NATURAL GAS

PROPANE GAS

3.5 TO 10.5 INCHES

8.0 TO 14.0 INCHES

* Supply pressures may vary unit to unit, refer to rating plate for exact pressure range



34

GAS PRESSURE CHECK

1) Locate and shut off gas valve

2) Zero manometer then connect to inlet port

3) Open gas valve and note static pressure

4) Create a high flow to ensure unit is in high fire and note dynamic pressure



- Check the pressure when the unit is sitting idle (Static Pressure)
- Check the pressure when the unit is in high fire (Dynamic Pressure)

Check the pressure on the gas connection or the bottom port of gas valve using T15 torx.



35

GAS LINE SIZING

PRO Series installation manuals contains 5 sizing tables for hard pipe gas lines, 4 for NG and 1 for LP.

To pick what NG chart you use, you will need to know the initial supply pressure.

Gas pipe sizing tables

- These tables are for reference only. Consult the gas pipe manufacturer for actual pipe capacities.
- These are examples for schedule 40 metallic pipe.
- (Only table 1-4) Values in Table are in ft³ of gas per hour. Contact your gas supplier for Btu/ft³ ratings. For simplification of your calculations, 1 ft³ of gas is approximately equivalent to 1,000 Btu/ft³.

1. Maximum Natural Gas Delivery Capacity (For Less than 6 in. W.C. initial supply pressure)																
0.5 in. W.C. Pressure Drop																
Pipe Size	Length (including fittings)															
	10 ft	20 ft	30 ft	40 ft	50 ft	60 ft	70 ft	80 ft	90 ft	100 ft	125 ft	150 ft	175 ft	200 ft		
1/2 in.	172	114	91	81	72	65	60	56	52	50	44	40	37	34		
3/4 in.	360	247	199	170	151	137	126	117	110	104	92	83	77	71		
1 in.	678	466	374	320	284	257	237	220	207	195	173	157	144	134		
1 1/4 in.	1,900	997	768	657	581	528	486	452	424	400	355	322	296	275		
1 1/2 in.	2,090	1,430	1,150	985	871	791	728	677	635	600	532	482	443	412		
2 in.	4,020	2,760	2,220	1,900	1,680	1,520	1,400	1,300	1,220	1,160	1,020	918	854	794		
2 1/2 in.	6,400	4,400	3,530	3,020	2,680	2,430	2,250	2,080	1,960	1,860	1,630	1,480	1,360	1,270		

2. Maximum Natural Gas Delivery Capacity (For 6.0 to 7.0 in. W.C. initial supply pressure)																
1.0 in. W.C. Pressure Drop																
Pipe Size	Length (including fittings)															
	10 ft	20 ft	30 ft	40 ft	50 ft	60 ft	70 ft	80 ft	90 ft	100 ft	125 ft	150 ft	175 ft	200 ft		
1/2 in.	260	172	138	118	105	95	87	81	76	72	64	58	53	50		
3/4 in.	524	360	289	247	219	199	183	170	160	151	134	121	111	104		
1 in.	986	678	544	466	411	374	344	320	300	284	252	228	210	195		
1 1/4 in.	2,030	1,390	1,120	957	848	768	707	657	617	581	516	468	430	400		
1 1/2 in.	2,240	1,560	1,260	1,080	960	870	800	740	700	660	580	530	490	460		
2 in.	4,440	3,000	2,400	2,000	1,800	1,650	1,540	1,450	1,380	1,320	1,160	1,040	970	910		
2 1/2 in.	6,800	4,600	3,700	3,100	2,700	2,400	2,200	2,000	1,880	1,780	1,540	1,390	1,290	1,210		

3. Maximum Natural Gas Delivery Capacity (For 8.0 to 10.0 in. W.C. initial supply pressure)																
1.5 in. W.C. Pressure Drop																
Pipe Size	Length (including fittings)															
	10 ft	20 ft	30 ft	40 ft	50 ft	60 ft	70 ft	80 ft	90 ft	100 ft	125 ft	150 ft	175 ft	200 ft		
1/2 in.	364	250	201	172	153	138	127	118	111	105	93	86	77	72		
3/4 in.	762	514	400	360	319	289	266	247	232	219	194	176	162	151		
1 in.	1,440	986	792	678	601	544	501	466	437	413	366	332	305	284		
1 1/4 in.	2,950	2,030	1,620	1,390	1,240	1,120	1,020	950	890	848	751	681	635	593		
1 1/2 in.	3,240	2,240	1,800	1,560	1,400	1,280	1,180	1,100	1,040	990	860	780	730	690		
2 in.	6,500	4,400	3,500	2,900	2,500	2,200	2,000	1,850	1,740	1,650	1,420	1,270	1,190	1,120		
2 1/2 in.	9,600	6,400	5,100	4,300	3,800	3,400	3,100	2,850	2,680	2,540	2,160	1,960	1,840	1,740		

4. Maximum Natural Gas Delivery Capacity (For 8.0 to 10.0 in. W.C. initial supply pressure)																
2.0 in. W.C. Pressure Drop																
Pipe Size	Length (including fittings)															
	10 ft	20 ft	30 ft	40 ft	50 ft	60 ft	70 ft	80 ft	90 ft	100 ft	125 ft	150 ft	175 ft	200 ft		
1/2 in.	464	312	263	214	190	172	157	145	135	127	110	101	91	85		
3/4 in.	949	652	524	448	397	360	331	308	289	273	242	219	202	188		
1 in.	1,790	1,230	986	844	740	678	624	580	544	514	456	413	380	353		
1 1/4 in.	3,430	2,310	1,800	1,560	1,400	1,280	1,180	1,100	1,040	990	860	780	730	690		
1 1/2 in.	3,720	2,500	2,000	1,760	1,600	1,480	1,380	1,300	1,240	1,190	1,020	910	860	810		
2 in.	7,400	5,000	4,000	3,400	3,000	2,700	2,500	2,300	2,150	2,040	1,720	1,540	1,440	1,360		
2 1/2 in.	10,800	7,200	5,800	5,000	4,400	4,000	3,700	3,440	3,200	3,000	2,500	2,240	2,090	1,960		
3 in.	16,000	11,000	8,800	7,600	6,800	6,200	5,800	5,400	5,100	4,800	4,100	3,700	3,400	3,200		

5. Maximum Unadiluted Propane (LP) Delivery Capacity (in Thousands of Btu/h)																
0.5 in. W.C. Pressure Drop																
Pipe Size	Length (including fittings)															
	10 ft	20 ft	30 ft	40 ft	50 ft	60 ft	70 ft	80 ft	90 ft	100 ft	125 ft	150 ft	175 ft	200 ft		
1/2 in.	291	200	150	137	122	110	101	94	89	84	74	67	61	57		
3/4 in.	608	418	336	287	255	231	212	197	185	175	151	135	124	116		
1 in.	1,150	787	632	541	480	436	401	374	352	331	289	262	241	224		
1 1/4 in.	2,350	1,620	1,300	1,130	985	892	821	763	716	677	600	543	503	471		
1 1/2 in.	2,520	1,720	1,380	1,200	1,050	950	870	810	760	710	610	550	500	460		
2 in.	5,000	3,400	2,700	2,300	2,000	1,800	1,650	1,540	1,450	1,380	1,160	1,040	970	910		
2 1/2 in.	7,200	4,900	3,900	3,300	2,900	2,600	2,350	2,200	2,090	1,990	1,660	1,480	1,390	1,310		



40 Connecting the Gas Supply

36

1/2" GAS LINE CONSIDERATIONS

After determining the initial supply pressure, you can use the charts to determine the maximum equivalent length of 1/2" hard pipe you may use based on the max btu of the unit.



1. Maximum Natural Gas Delivery Capacity (For Less than 6 in. W.C. initial supply pressure)																	
0.5 in. W.C. Pressure Drop																	
Pipe Size	Length (including fittings)																
	10 ft (3 m)	20 ft (6 m)	30 ft (9 m)	40 ft (12 m)	50 ft (15 m)	60 ft (18 m)	70 ft (21 m)	80 ft (24 m)	90 ft (27 m)	100 ft (30 m)	125 ft (38 m)	150 ft (45 m)	175 ft (53 m)	200 ft (60 m)			
1/2 in.	172	118	95	81	72	65	60	56	52	50	44	40	37	34			
3/4 in.	360	247	199	170	151	137	126	117	110	104	92	83	77	71			
1 in.	678	466	374	320	284	257	237	220	207	195	173	157	144	134			
1 1/4 in.	1,390	957	768	657	583	528	486	452	424	400	355	322	296	275			
1 1/2 in.	2,090	1,430	1,150	985	873	791	728	677	635	600	532	482	443	412			
2 in.	4,020	2,760	2,220	1,900	1,680	1,520	1,400	1,300	1,220	1,160	1,020	928	854	794			
2 1/2 in.	6,400	4,400	3,530	3,020	2,680	2,430	2,230	2,080	1,950	1,840	1,630	1,480	1,374	1,290			

2. Maximum Natural Gas Delivery Capacity (For 6 - 7 in. W.C. initial supply pressure)																	
1.0 in. W.C. Pressure Drop																	
Pipe Size	Length (including fittings)																
	10 ft (3 m)	20 ft (6 m)	30 ft (9 m)	40 ft (12 m)	50 ft (15 m)	60 ft (18 m)	70 ft (21 m)	80 ft (24 m)	90 ft (27 m)	100 ft (30 m)	125 ft (38 m)	150 ft (45 m)	175 ft (53 m)	200 ft (60 m)			
1/2 in.	250	172	138	118	105	95	87	81	76	72	64	58	53	50			
3/4 in.	524	360	289	247	219	199	183	170	160	151	134	121	111	104			
1 in.	986	678	544	466	413	374	344	320	300	284	252	228	210	195			
1 1/4 in.	2,030	1,390	1,120	957	848	768	707	657	617	583	516	468	430	400			
1 1/2 in.	3,030	2,090	1,680	1,430	1,270	1,150	1,060	989	924	873	774	701	645	600			
2 in.	5,840	4,020	3,230	2,760	2,450	2,220	2,040	1,900	1,780	1,680	1,490	1,350	1,240	1,160			
2 1/2 in.	9,310	6,400	5,140	4,400	3,900	3,530	3,250	3,020	2,840	2,680	2,380	2,150	1,980	1,840			

3. Maximum Natural Gas Delivery Capacity (For 7 - 8 in. W.C. initial supply pressure)																	
2.0 in. W.C. Pressure Drop																	
Pipe Size	Length (including fittings)																
	10 ft (3 m)	20 ft (6 m)	30 ft (9 m)	40 ft (12 m)	50 ft (15 m)	60 ft (18 m)	70 ft (21 m)	80 ft (24 m)	90 ft (27 m)	100 ft (30 m)	125 ft (38 m)	150 ft (45 m)	175 ft (53 m)	200 ft (60 m)			
1/2 in.	364	250	201	172	153	138	127	118	111	105	93	84	77	72			
3/4 in.	762	524	420	360	319	289	266	247	232	219	194	176	162	151			
1 in.	1,440	986	792	678	601	544	501	466	437	413	366	332	305	284			
1 1/4 in.	2,950	2,030	1,630	1,390	1,230	1,120	1,030	957	898	848	751	681	626	583			
1 1/2 in.	4,420	3,030	2,440	2,090	1,850	1,680	1,540	1,430	1,350	1,270	1,130	1,020	938	873			
2 in.	8,500	5,840	4,690	4,020	3,560	3,230	2,970	2,760	2,590	2,450	2,170	1,970	1,810	1,680			
2 1/2 in.	13,600	9,310	7,480	6,400	5,670	5,140	4,730	4,400	4,130	3,900	3,460	3,130	2,880	2,680			

4. Maximum Natural Gas Delivery Capacity (For 8 - 10.5 in. W.C. initial supply pressure)																	
3.0 in. W.C. Pressure Drop																	
Pipe Size	Length (including fittings)																
	10 ft (3 m)	20 ft (6 m)	30 ft (9 m)	40 ft (12 m)	50 ft (15 m)	60 ft (18 m)	70 ft (21 m)	80 ft (24 m)	90 ft (27 m)	100 ft (30 m)	125 ft (38 m)	150 ft (45 m)	175 ft (53 m)	200 ft (60 m)			
1/2 in.	454	312	250	214	190	172	158	147	138	131	116	105	96	90			
3/4 in.	949	652	524	448	397	360	331	308	289	273	242	219	202	188			
1 in.	1,790	1,230	986	844	748	678	624	580	544	514	456	413	380	353			
1 1/4 in.	3,670	2,520	2,030	1,730	1,540	1,390	1,280	1,190	1,120	1,060	936	848	780	726			
1 1/2 in.	5,500	3,780	3,030	2,600	2,300	2,090	1,920	1,790	1,680	1,580	1,400	1,270	1,170	1,090			
2 in.	10,600	7,280	5,840	5,000	4,430	4,020	3,700	3,440	3,230	3,050	2,700	2,450	2,250	2,090			
2 1/2 in.	16,900	11,600	9,310	7,970	7,070	6,400	5,890	5,480	5,140	4,860	4,300	3,900	3,590	3,340			

37

1/2" GAS LINE CONSIDERATIONS

The higher the initial supply pressure, the longer the 1/2" gas line can be.

Highlighted areas indicate max equivalent length for an EZ71DV (160k btu max). Equivalent length factors in elbows and fittings, not just straight pipe.



1. Maximum Natural Gas Delivery Capacity (For Less than 6 in. W.C. initial supply pressure)																	
0.5 in. W.C. Pressure Drop																	
Pipe Size	Length (including fittings)																
	10 ft (3 m)	20 ft (6 m)	30 ft (9 m)	40 ft (12 m)	50 ft (15 m)	60 ft (18 m)	70 ft (21 m)	80 ft (24 m)	90 ft (27 m)	100 ft (30 m)	125 ft (38 m)	150 ft (45 m)	175 ft (53 m)	200 ft (60 m)			
1/2 in.	172	118	95	81	72	65	60	56	52	50	44	40	37	34			
3/4 in.	360	247	199	170	151	137	126	117	110	104	92	83	77	71			
1 in.	678	466	374	320	284	257	237	220	207	195	173	157	144	134			
1 1/4 in.	1,390	957	768	657	583	528	486	452	424	400	355	322	296	275			
1 1/2 in.	2,090	1,430	1,150	985	873	791	728	677	635	600	532	482	443	412			
2 in.	4,020	2,760	2,220	1,900	1,680	1,520	1,400	1,300	1,220	1,160	1,020	928	854	794			
2 1/2 in.	6,400	4,400	3,530	3,020	2,680	2,430	2,230	2,080	1,950	1,840	1,630	1,480	1,360	1,290			

2. Maximum Natural Gas Delivery Capacity (For 6 - 7 in. W.C. initial supply pressure)																	
1.0 in. W.C. Pressure Drop																	
Pipe Size	Length (including fittings)																
	10 ft (3 m)	20 ft (6 m)	30 ft (9 m)	40 ft (12 m)	50 ft (15 m)	60 ft (18 m)	70 ft (21 m)	80 ft (24 m)	90 ft (27 m)	100 ft (30 m)	125 ft (38 m)	150 ft (45 m)	175 ft (53 m)	200 ft (60 m)			
1/2 in.	250	172	138	118	105	95	87	81	76	72	64	58	53	50			
3/4 in.	524	360	289	247	219	199	183	170	160	151	134	121	111	104			
1 in.	986	678	544	466	413	374	344	320	300	284	252	228	210	195			
1 1/4 in.	2,030	1,390	1,120	957	848	768	707	657	617	583	516	468	430	400			
1 1/2 in.	3,030	2,090	1,680	1,430	1,270	1,150	1,060	989	924	873	774	701	645	600			
2 in.	5,840	4,020	3,230	2,760	2,450	2,220	2,040	1,900	1,780	1,680	1,490	1,350	1,240	1,160			
2 1/2 in.	9,310	6,400	5,140	4,400	3,900	3,530	3,250	3,020	2,840	2,680	2,380	2,150	1,980	1,840			

3. Maximum Natural Gas Delivery Capacity (For 7 - 8 in. W.C. initial supply pressure)																	
2.0 in. W.C. Pressure Drop																	
Pipe Size	Length (including fittings)																
	10 ft (3 m)	20 ft (6 m)	30 ft (9 m)	40 ft (12 m)	50 ft (15 m)	60 ft (18 m)	70 ft (21 m)	80 ft (24 m)	90 ft (27 m)	100 ft (30 m)	125 ft (38 m)	150 ft (45 m)	175 ft (53 m)	200 ft (60 m)			
1/2 in.	364	250	201	172	153	138	127	118	111	105	93	84	77	72			
3/4 in.	762	524	420	360	319	289	266	247	232	219	194	176	162	151			
1 in.	1,440	986	792	678	601	544	501	466	437	413	366	332	305	284			
1 1/4 in.	2,950	2,030	1,630	1,390	1,230	1,120	1,030	957	898	848	751	681	626	583			
1 1/2 in.	4,420	3,030	2,440	2,090	1,850	1,680	1,540	1,430	1,350	1,270	1,130	1,020	938	873			
2 in.	8,500	5,840	4,690	4,020	3,560	3,230	2,970	2,760	2,590	2,450	2,170	1,970	1,810	1,680			
2 1/2 in.	13,600	9,310	7,480	6,400	5,670	5,140	4,730	4,400	4,130	3,900	3,460	3,130	2,880	2,680			

4. Maximum Natural Gas Delivery Capacity (For 8 - 10.5 in. W.C. initial supply pressure)																	
3.0 in. W.C. Pressure Drop																	
Pipe Size	Length (including fittings)																
	10 ft (3 m)	20 ft (6 m)	30 ft (9 m)	40 ft (12 m)	50 ft (15 m)	60 ft (18 m)	70 ft (21 m)	80 ft (24 m)	90 ft (27 m)	100 ft (30 m)	125 ft (38 m)	150 ft (45 m)	175 ft (53 m)	200 ft (60 m)			
1/2 in.	454	312	250	214	190	172	158	147	138	131	116	105	96	90			
3/4 in.	949	652	524	448	397	360	331	308	289	273	242	219	202	188			
1 in.	1,790	1,230	986	844	748	678	624	580	544	514	456	413	380	353			
1 1/4 in.	3,670	2,520	2,030	1,730	1,540	1,390	1,280	1,190	1,120	1,060	936	848	780	726			
1 1/2 in.	5,500	3,780	3,030	2,600	2,300	2,090	1,920	1,790	1,680	1,580	1,400	1,270	1,170	1,090			
2 in.	10,600	7,280	5,840	5,000	4,430	4,020	3,700	3,440	3,230	3,050	2,700	2,450	2,250	2,090			
2 1/2 in.	16,900	11,600	9,310	7,970	7,070	6,400	5,890	5,480	5,140	4,860	4,300	3,900	3,590	3,340			

38

DEDICATED OR BRANCH GAS LINE?

Both Dedicated and Branching from an existing gas line are acceptable choices.



39

DEDICATED OR BRANCH GAS LINE?

However, if you branch off the existing gas line, you need to make sure all sections of the line can support the btu demand.

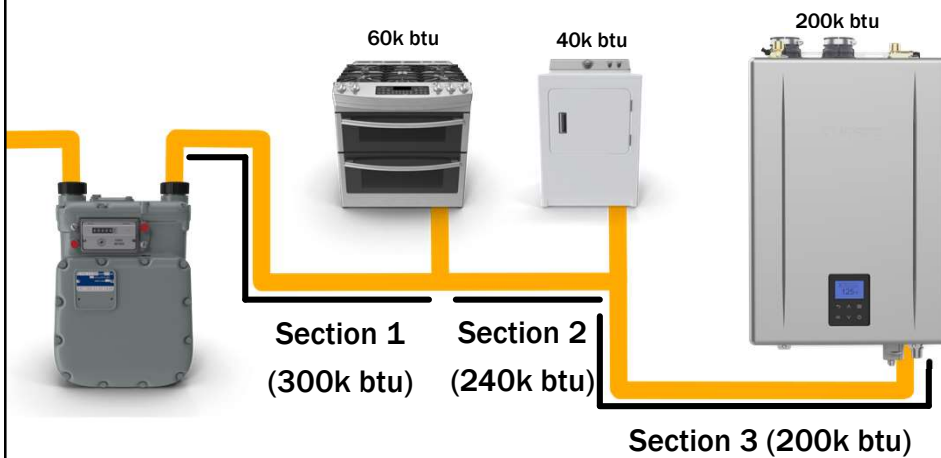

40

DEDICATED OR BRANCH GAS LINE?

Also make sure the gas meter can supply the total btu demand of the home.

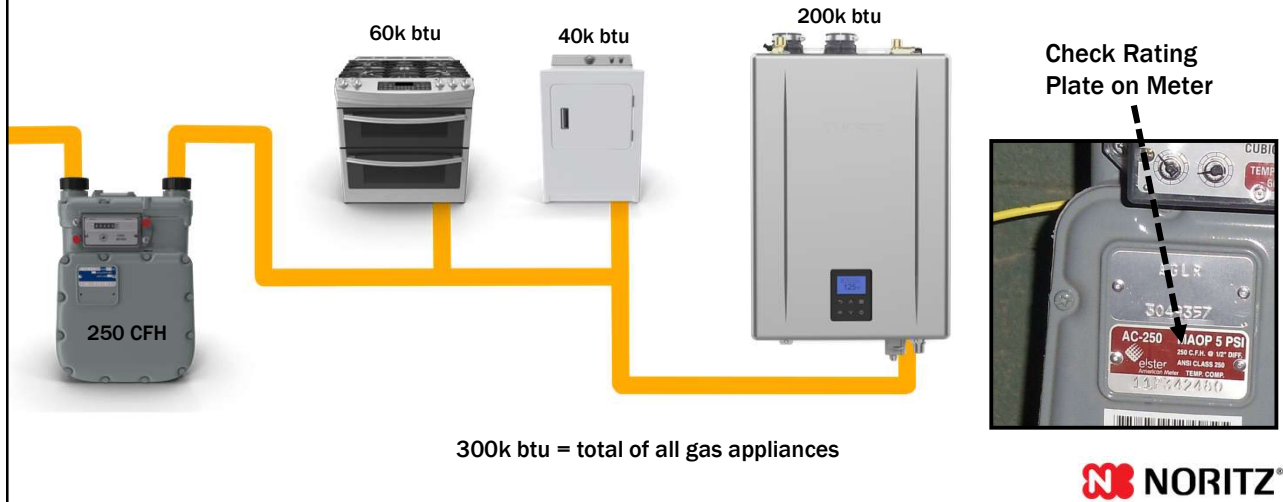

41

DEDICATED OR BRANCH GAS LINE?

In some cases, it may need to be upsized to handle the added demand of the tankless unit.

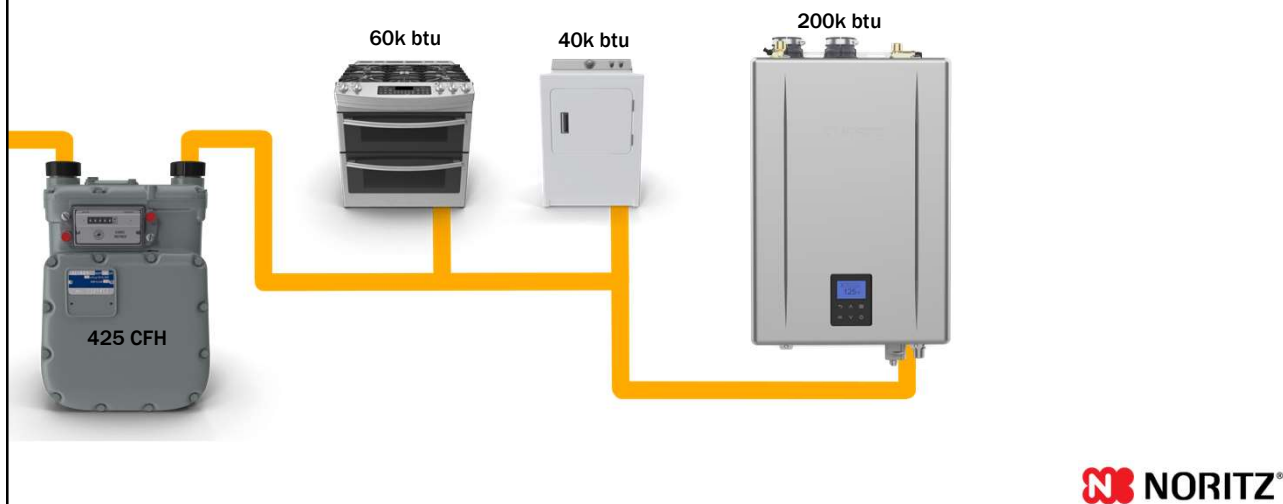

42

PROPANE TANK & ORIFICE

IF GAUGE READS	250 GAL TANK	500 GAL TANK
80%	200	400
70%	175	350
60%	150	300
50%	125	250
40%	100	200
30%	75	150

PROPANE GAS
8.0 TO 13.0 INCHES

If using the PRO Series units only an Orifice Change and programming with EZ Start Plus App is needed. LP Orifice is included with the unit.



Gauge at 82% or above is considered full

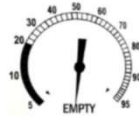

Gauge appears to be empty, if tank is completely empty sometimes a leak test is required which comes with a fee. So fill tank before its empty to avoid this.



NORITZ

43

CHOOSING INSTALLATION LOCATION



Now that you've sized out the perfect unit for the job and made sure the gas system can support the new tankless, it's time to pick the perfect installation location.

NORITZ

44

CHOOSING INSTALLATION LOCATION



For cold climates where snow is a regular or even occasional occurrence, you'll want to install the unit indoors.



45

CHOOSING INSTALLATION LOCATION



For warm climates that never see freezing weather, installing the unit outdoors is a great way to free up space inside the home.



46

CHOOSING INSTALLATION LOCATION



Keep in mind all tankless water heaters have motorized parts. When in operation they *are* fairly quiet, but the noises may bother some customers so keep that in mind when scouting a location to install the unit.



47

CHOOSING INSTALLATION LOCATION



If possible, avoid installing the unit on a bedroom wall or other areas where customers might expect a quiet space.



48

INDOOR VENTING OPTIONS

When installing the unit indoors, you have a few different venting options available to you although they will generally fall into 1 of 2 categories:

DV Direct Vent

SV Single Vent



49

INDOOR VENTING OPTIONS



Direct Vent Examples:



Two Pipes
To Outside



Concentric
Terminations



DVC Style
Unit

50

INDOOR VENTING OPTIONS



Single Vent Examples:



DV to SV
Conversion



Flex Vent
Kit



SV Style
Unit

51

HORIZONTAL OR VERTICAL VENTING



All Noritz indoor units may be vented either horizontally or vertically regardless of SV or DV vent type, with the only exception being the EZTR packages that use the 2" flexible vent.



52

VENTING MATERIAL



Standard efficiency non-condensing units must be vented with category III stainless steel venting and high efficiency condensing models may use plastic venting such as PVC, CPVC or PP depending on code requirements.



Non-Condensing Model



Condensing Model

53

PVC VENTING



Horizontal Exhaust runs should pitch towards the unit to allow condensation to drain in the unit and out the trap.

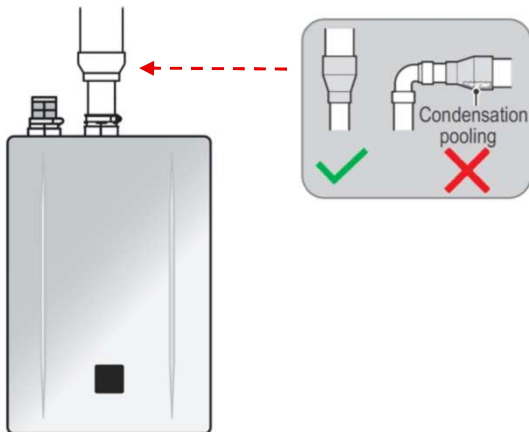

Long Sweep Turns vs Short Radius Turns

Long sweep 90° creates a smooth transition of the exhaust gases from one direction to another

Long sweep 90° causes the least amount of turbulence.

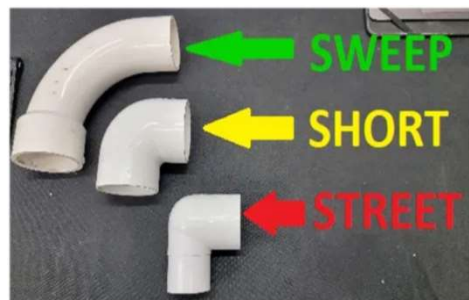

54

PRO SERIES VENTING OPTIONS



One SKU, All Venting Options.

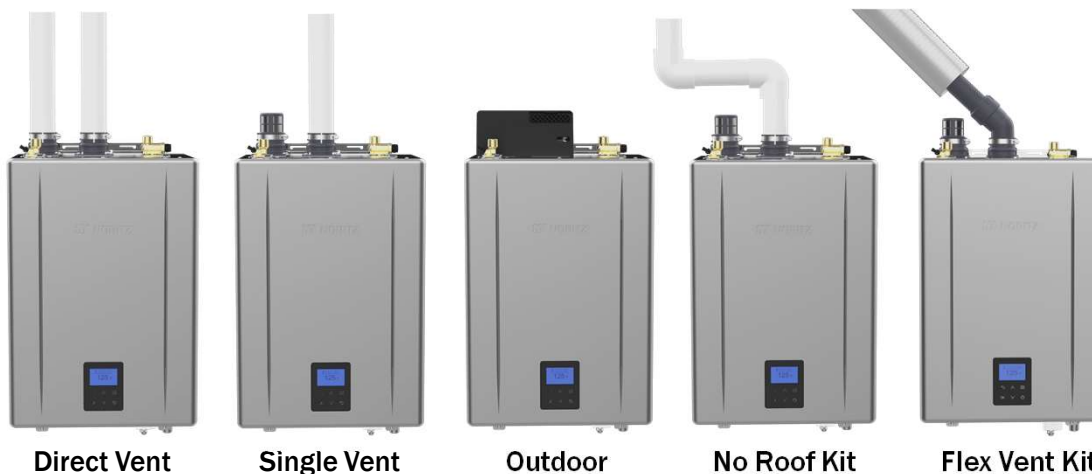

Direct Vent

Single Vent

Outdoor

No Roof Kit

Flex Vent Kit

55

PRO SERIES VENTING OPTIONS

DV – Direct Vent



Ideal For:

- Areas with dirty combustion air
- Tight locations without combustion air
- When unit is installed in a conditioned space (Why draw conditioned air through the unit?)



56

PRO SERIES VENTING OPTIONS

SV – Single Vent



Ideal For:

- Areas with clean combustion air
- Areas with plenty of combustion air



57

PRO SERIES VENTING OPTIONS

OD – Outdoor



Ideal For:

- Warm climates without snow
- Reclaiming space in the home



58

PRO SERIES VENTING OPTIONS

NRK – No Roof Kit



Ideal For:

- Straight up b-vent runs 8.5' or under
- Tank Retrofits
- Saving time by not replacing venting or getting on the roof



Scan for NRK-1
Install Video



59

PRO SERIES VENTING OPTIONS

FSV – Flexible Single Vent



Ideal For:

- B-vent runs with 45 degree turns
- B-vent runs 5' to 35'
- Tank Retrofits
- Saving time by not replacing venting



60

EZTR FLEX VENTING

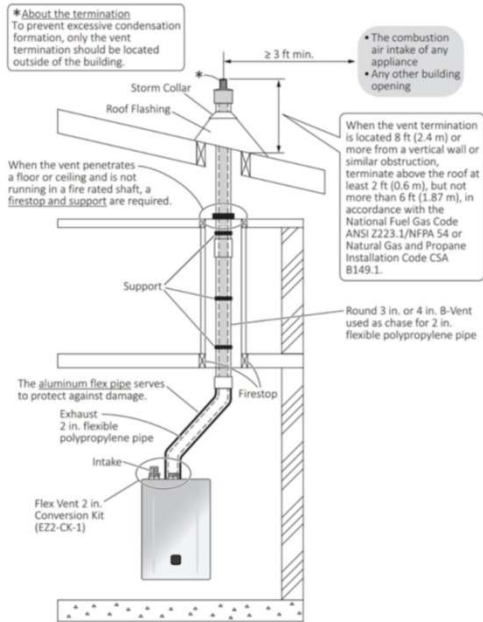

EZTR installations *must* be run vertically through the existing round b-vent and *cannot* be run horizontally.



61

WHEN TO DIRECT VENT

When combustion air is likely to be contaminated, such as in:

Attics



Laundry Rooms



Commercial Kitchens



It's best to install a Direct Vent unit.



62

WHEN TO DIRECT VENT



Pulling in dirty combustion air with an SV unit will require quite a bit of preventative maintenance and likely shorten the overall lifespan of the unit.



63

2 PIPE TERMINATION OPTIONS



Direct Vent Horizontal

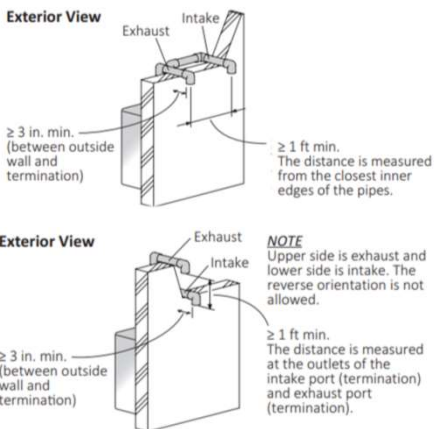

Using 90 PVC elbows the distance between the intake and exhaust is 1 ft

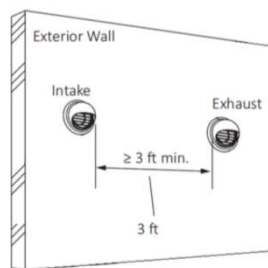

Using PVT-HL terminations the distance between the intake and exhaust is 3 ft

Direct Vent Vertical

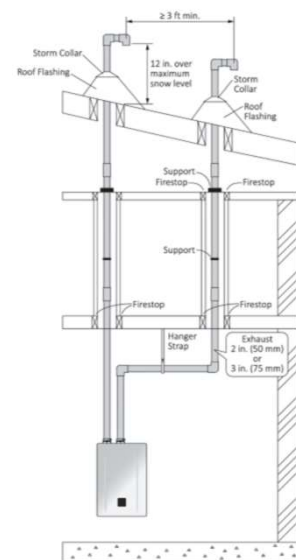

64

CONCENTRIC HORIZONTAL TERMINATION

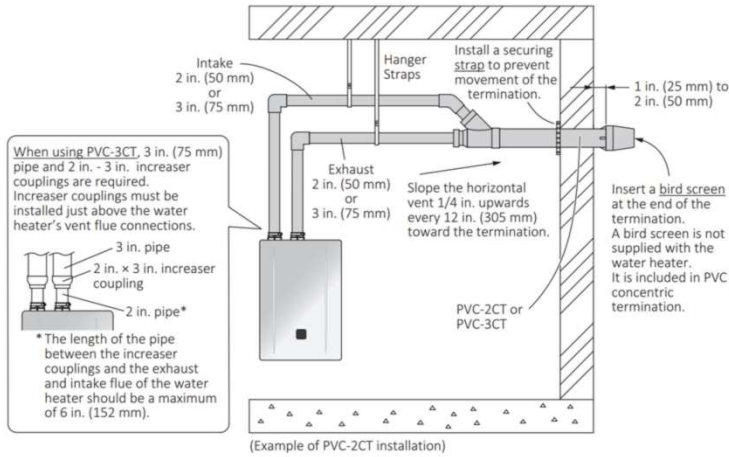

- PVC-2CT: 2" Connections
- PVC-3CT: 3" Connections



65

CONCENTRIC HORIZONTAL TERMINATION

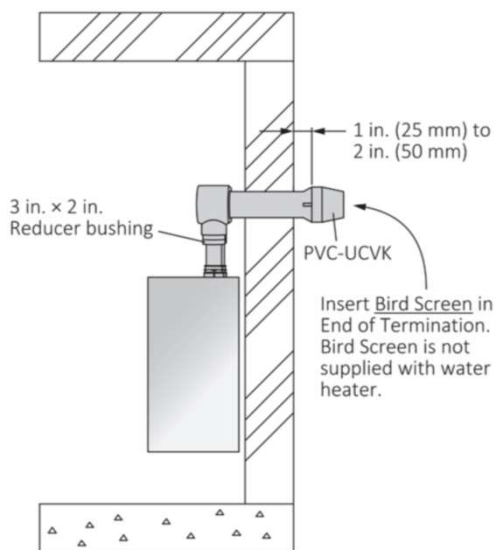

PVC-UCVK: For easy up and out venting



66

CONCENTRIC HORIZONTAL TERMINATION

(e.g. PVT-2LPT installation)

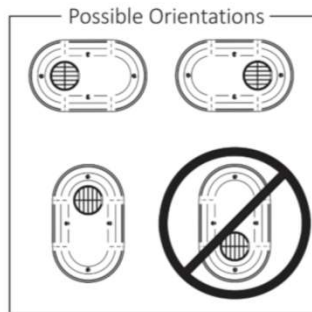
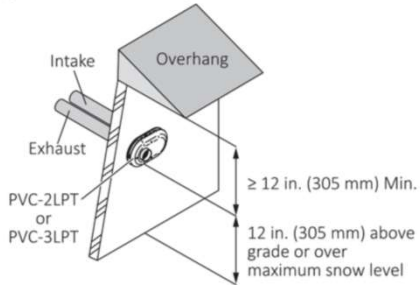

- PVC-2LPT: 2" Connections
- PVC-3LPT: 3" Connections



67

CONCENTRIC VERTICAL TERMINATION

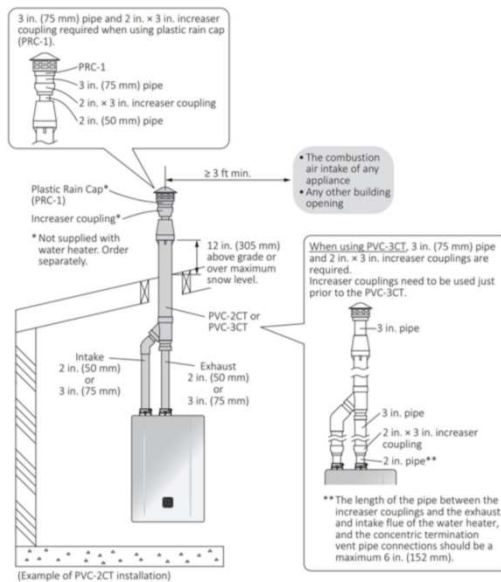

- PVC-2CT: 2" Connections
- PVC-3CT: 3" Connections
- PRC-1: Plastic Rain Cap



68

SV TERMINATION OPTIONS

If the installation location meets the combustion air requirements in the manual, you have the option to install a Single Vent unit or use the SV conversion kit on a compatible DV unit and run a single exhaust vent to the outside.



EZ111DV (GQ-C3261WX-FF-1 US)		
Indoor make up air is provided		200 in. ²
	Example (W) × (H)	20 in. × 10 in.
Outdoor make up air is provided	Direct or Vertical ducts	50 in. ²
	Example (W) × (H)	10 in. × 5 in.
	Horizontal ducts	100 in. ²
	Example (W) × (H)	20 in. × 5 in.

EZ98DV (GQ-C2861WX-FF-1 US)		
Indoor make up air is provided		180 in. ²
	Example (W) × (H)	20 in. × 9 in.
Outdoor make up air is provided	Direct or Vertical ducts	45 in. ²
	Example (W) × (H)	10 in. × 4 1/2 in.
	Horizontal ducts	90 in. ²
	Example (W) × (H)	20 in. × 4 1/2 in.

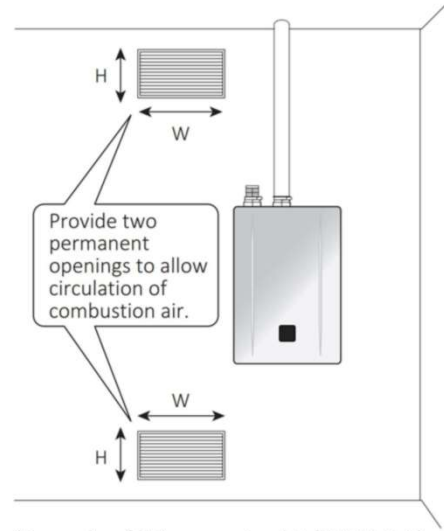

(Example of SV conversion kit (SV-CK-2-1) installation)



69

OUTDOOR INSTALL CONSIDERATIONS

Outdoor installations are probably one of the easiest options if the climate allows. However, there are still things to consider such as clearances to building openings and how close the unit is to a neighboring building. The last thing you want is for the exhaust or operational noises to affect the neighbors.

When installing the water heater in a common side corridor

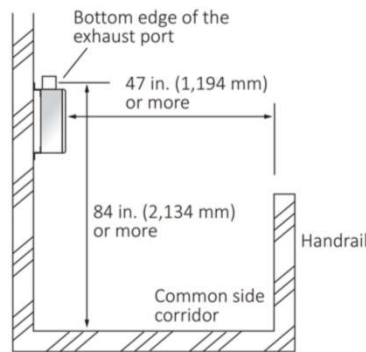

70

COMMON VENTING 2 PRO SERIES UNITS

The EZ PRO and NRCR PRO units can be common vented

Common Vent

This water heater is suitable for a common vent system. To make a common vent system, contact Noritz America at 1-866-766-7489 or scan the following two-dimensional barcode and then refer to the common vent installation manual for detailed information.



Common Direct Vent

Set the vent type setting to "Common Direct Vent".

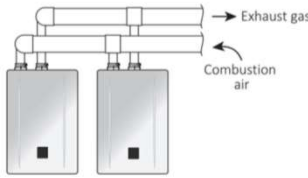

Model	Number of Units	Vent Diameter (inch) and Maximum Equivalent Vent Length (feet)			
		PVC or CPVC Schedule 40 Pipe / Polypropylene vent			
		3 Inch	4 Inch	6 Inch	8 Inch
EZ71, EZ98 & EZ111 NRCR92 & NRCR111	2	65*	200*	200	200
		Equivalent Length of each Elbow (feet)			
Diameter of Elbow		3 Inch	4 Inch	6 Inch	8 Inch
Length		5	12	18	20

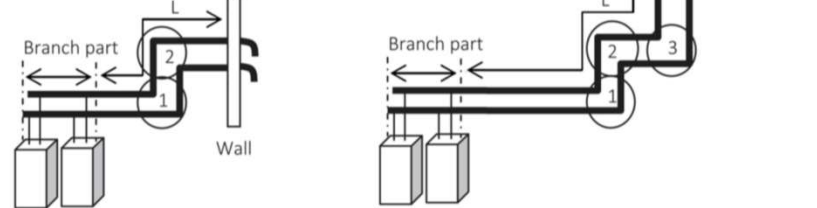

*The Btu/h input of the unit will be reduced by up to 9%.



INSTALLATION CLEARANCE REQUIREMENTS

6.4 Vent Pipe Installation (Direct Vent)

6.4.1 Clearance Requirements from Vent Terminations to Building Openings

(When supplying combustion air from the outdoors)

All clearance requirements are in accordance with ANSI Z223.1-10.3 and the National Fuel Gas Code, ANSI Z223.1 and in Canada, in accordance with the National Gas and Propane Installation Code CSA B149.1.

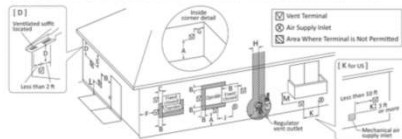

Ref.	Description	Canadian Direct Vent installations - I	US Direct Vent installations - I
A	Clearance above grade, veranda, porch, deck, or balcony	12 in. (30 cm)	12 in. (30 cm)
B	Clearance to window or door that may be opened	6 ft. (183 cm) for appliances $\le 150,000 \text{ Btu/h (43 kW)}$ 12 in. (30 cm) for appliances > 150,000 Btu/h (43 kW) and $\le 1,000,000 \text{ Btu/h (293 kW)}$ 36 in. (91 cm) for appliances > 1,000,000 Btu/h (293 kW)	6 ft. (183 cm) for appliances $\le 150,000 \text{ Btu/h (43 kW)}$ 8 in. (20 cm) for appliances > 150,000 Btu/h (43 kW) and $\le 1,000,000 \text{ Btu/h (293 kW)}$ 12 in. (30 cm) for appliances > 1,000,000 Btu/h (293 kW)
C	Clearance to permanently closed window	-	-
D	Vertical clearance to ventilated soffit located above the termination within a horizontal distance of 2 feet (61 cm) from the center line of the terminal	-	-
E	Clearance to unventilated soffit	-	-
F	Clearance to outside corner	-	-
G	Clearance to inside corner	-	-
H	Clearance to each side of center line extended above multi-regulator assembly	-	-
I	Clearance to service regulator vent outlet	Above a regulator within 3 ft (91 cm) horizontally of the vertical center line of the regulator vent outlet to a maximum vertical distance of 15 ft (4.5 m)	-
J	Clearance to non-mechanical air supply riser to building or the combustion air inlet to any other appliance	6 ft. (183 cm) for appliances $\le 150,000 \text{ Btu/h (43 kW)}$ 12 in. (30 cm) for appliances > 150,000 Btu/h (43 kW) and $\le 1,000,000 \text{ Btu/h (293 kW)}$ 36 in. (91 cm) for appliances > 1,000,000 Btu/h (293 kW)	6 ft. (183 cm) for appliances $\le 150,000 \text{ Btu/h (43 kW)}$ 8 in. (20 cm) for appliances > 150,000 Btu/h (43 kW) and $\le 1,000,000 \text{ Btu/h (293 kW)}$ 12 in. (30 cm) for appliances > 1,000,000 Btu/h (293 kW)
K	Clearance to a mechanical air supply riser	6 ft. (1.83 m)	3 ft. (91 cm) above if within 10 ft. (3 m) horizontally
L	Clearance above paved sidewalk or paved driveway located on public property	7 ft. (2.13 m)*	-
M	Clearance under veranda, porch, deck, or balcony	12 in. (30 cm)†	-

I In accordance with the current CSA B149.1 National Gas and Propane Installation Code
 † In accordance with the current ANSI Z223.1 / NFPA 54 National Fuel Gas Code
 * A vent shall not terminate directly above a sidewalk or paved driveway that is located between two single-family dwellings and serves both dwellings.
 ‡ Minimum only if veranda, porch, deck, or balcony fully opens on a minimum of two sides beneath the floor.
 * Clearance in accordance with local installation codes and the requirements of the gas supplier. Clearance to opposite wall is 24 in. (60 cm)

The terminations of all gas burning appliances are subject to National Fuel Gas Codes clearance requirements to building openings. The installation manual provides these diagrams and many clearance requirements directly from the national fuel gas code for both US and Canada.



INSTALLATION CLEARANCE REQUIREMENTS

6.4 Vent Pipe Installation (Direct Vent)

6.4.1 Clearance Requirements from Vent Terminations to Building Openings (When supplying combustion air from the outdoors)

All clearance requirements are in accordance with ANS Z21.10.3 and the National Fuel Gas Code, ANSI Z223.1 and in Canada, in accordance with the Natural Gas and Propane Installation Code, CSA B149.1.

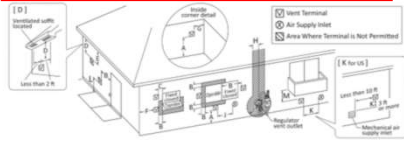

Ref.	Description	Canadian Direct Vent Installations †	US Direct Vent Installations †
A	Clearance above grade, veranda, porch, deck, or balcony	12 in. (30 cm)	12 in. (30 cm)
B	Clearance to window or door that may be opened	6 ft. (1.83 m) for appliances < 10,000 Btu/h (3 kW) 12 in. (30 cm) for appliances > 10,000 Btu/h (3 kW) and < 100,000 Btu/h (30 kW) 36 in. (91 cm) for appliances > 100,000 Btu/h (30 kW)	6 ft. (1.83 m) for appliances < 10,000 Btu/h (3 kW) 8 ft. (2.44 m) for appliances > 10,000 Btu/h (3 kW) and < 100,000 Btu/h (30 kW) 12 in. (30 cm) for appliances > 100,000 Btu/h (30 kW)
C	Clearance to permanently closed window	-	-
D	Vertical clearance to ventilated soffit located above the terminal within a horizontal distance of 2 feet (61 cm) from the center line of the terminal	-	-
E	Clearance to unventilated soffit	-	-
F	Clearance to outside corner	-	-
G	Clearance to inside corner	-	-
H	Clearance to each side of center line extended above meter/regulator assembly	-	-
I	Clearance to service regulator vent outlet	Above a regulator within 3 ft. (91 cm) horizontally of the vertical center line of the regulator vent outlet to a maximum vertical distance of 15 ft. (4.5 m)	-
J	Clearance to non-mechanical air supply inlet to building or the combustion air inlet to any other appliance	6 ft. (1.83 m) for appliances < 10,000 Btu/h (3 kW) 12 in. (30 cm) for appliances > 10,000 Btu/h (3 kW) and < 100,000 Btu/h (30 kW) 36 in. (91 cm) for appliances > 100,000 Btu/h (30 kW)	6 ft. (1.83 m) for appliances < 10,000 Btu/h (3 kW) 8 ft. (2.44 m) for appliances > 10,000 Btu/h (3 kW) and < 100,000 Btu/h (30 kW) 12 in. (30 cm) for appliances > 100,000 Btu/h (30 kW)
K	Clearance to a mechanical air supply inlet	6 ft. (1.83 m)	3 ft. (91 cm) above if within 10 ft. (3 m) horizontally
L	Clearance above paved sidewalk or paved driveway located on public property	7 ft. (2.13 m)*	-
M	Clearance under veranda, porch, deck, or balcony	12 in. (30 cm)†	-

† In accordance with the current CSA B149.1 Natural Gas and Propane Installation Code
 ‡ In accordance with the current ANSI Z223.1 / NFPA 54 National Fuel Gas Code
 * A vent shall not terminate directly above a sidewalk or paved driveway that is located between two single family dwellings and serves both dwellings.
 † Restricted only if veranda, porch, deck, or balcony is fully open on a minimum of two sides beneath the floor.
 ‡ Clearance in accordance with local installation codes and the requirements of the gas supplier. Clearance to opposite wall is 24 in. (60 cm).

It's important to note that Noritz does not make these clearance requirements and thus cannot overrule any local, state, provincial or national code. When there is no national code clearance listed, local code or the requirements of the gas supplier must be followed.



INSTALLATION CLEARANCE REQUIREMENTS

6.4 Vent Pipe Installation (Direct Vent)

6.4.1 Clearance Requirements from Vent Terminations to Building Openings (When supplying combustion air from the outdoors)

All clearance requirements are in accordance with ANS Z21.10.3 and the National Fuel Gas Code, ANSI Z223.1 and in Canada, in accordance with the Natural Gas and Propane Installation Code, CSA B149.1.

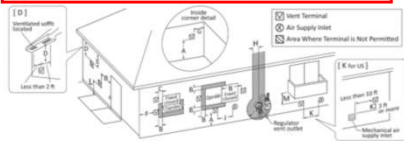

Ref.	Description	Canadian Direct Vent Installations †	US Direct Vent Installations †
A	Clearance above grade, veranda, porch, deck, or balcony	12 in. (30 cm)	12 in. (30 cm)
B	Clearance to window or door that may be opened	6 ft. (1.83 m) for appliances < 10,000 Btu/h (3 kW) 12 in. (30 cm) for appliances > 10,000 Btu/h (3 kW) and < 100,000 Btu/h (30 kW) 36 in. (91 cm) for appliances > 100,000 Btu/h (30 kW)	6 ft. (1.83 m) for appliances < 10,000 Btu/h (3 kW) 8 ft. (2.44 m) for appliances > 10,000 Btu/h (3 kW) and < 100,000 Btu/h (30 kW) 12 in. (30 cm) for appliances > 100,000 Btu/h (30 kW)
C	Clearance to permanently closed window	-	-
D	Vertical clearance to ventilated soffit located above the terminal within a horizontal distance of 2 feet (61 cm) from the center line of the terminal	-	-
E	Clearance to unventilated soffit	-	-
F	Clearance to outside corner	-	-
G	Clearance to inside corner	-	-
H	Clearance to each side of center line extended above meter/regulator assembly	-	-
I	Clearance to service regulator vent outlet	Above a regulator within 3 ft. (91 cm) horizontally of the vertical center line of the regulator vent outlet to a maximum vertical distance of 15 ft. (4.5 m)	-
J	Clearance to non-mechanical air supply inlet to building or the combustion air inlet to any other appliance	6 ft. (1.83 m) for appliances < 10,000 Btu/h (3 kW) 12 in. (30 cm) for appliances > 10,000 Btu/h (3 kW) and < 100,000 Btu/h (30 kW) 36 in. (91 cm) for appliances > 100,000 Btu/h (30 kW)	6 ft. (1.83 m) for appliances < 10,000 Btu/h (3 kW) 8 ft. (2.44 m) for appliances > 10,000 Btu/h (3 kW) and < 100,000 Btu/h (30 kW) 12 in. (30 cm) for appliances > 100,000 Btu/h (30 kW)
K	Clearance to a mechanical air supply inlet	6 ft. (1.83 m)	3 ft. (91 cm) above if within 10 ft. (3 m) horizontally
L	Clearance above paved sidewalk or paved driveway located on public property	7 ft. (2.13 m)*	-
M	Clearance under veranda, porch, deck, or balcony	12 in. (30 cm)†	-

† In accordance with the current CSA B149.1 Natural Gas and Propane Installation Code
 ‡ In accordance with the current ANSI Z223.1 / NFPA 54 National Fuel Gas Code
 * A vent shall not terminate directly above a sidewalk or paved driveway that is located between two single family dwellings and serves both dwellings.
 † Restricted only if veranda, porch, deck, or balcony is fully open on a minimum of two sides beneath the floor.
 ‡ Clearance in accordance with local installation codes and the requirements of the gas supplier. Clearance to opposite wall is 24 in. (60 cm).

These codes are designed to prevent the exhaust from a gas burning appliance from entering the home and putting the occupants at risk.



CONDENSATE DRAIN CONNECTION

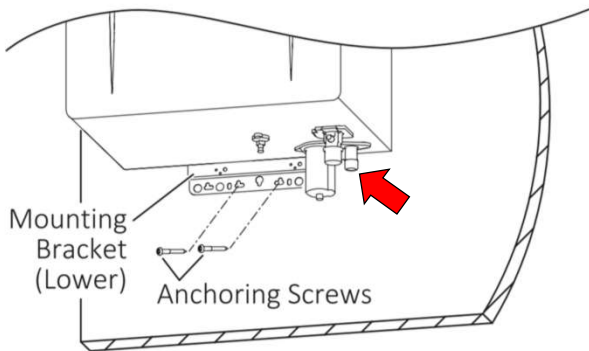

Condensing heaters will have a 1/2" condensate drain connection on the bottom of the unit.



75

CONDENSATE DRAIN CONNECTION

Condensate drain piping

Make the condensate drain piping run as short as possible.

NOTE Do not make a trap.



The condensate drain line should be as short and direct as possible and you do not need to create a trap as that's what the collector inside the unit does.

Adding an air vent on the condensate line will help with draining the condensate and not backing up into the unit.



76

CONDENSATE DRAIN CONNECTION

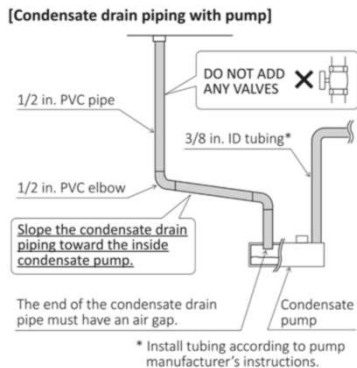

Long runs or applications where the nearest drain is above the Water Heater

Require the use of a condensate pump.
Size the pump to allow for a maximum condensate discharge of 2 GPH from the Water Heater.

If the desired drain location is a long distance from or above the heater, a condensate pump should be used. The pump should be sized to handle 2 gallons per hour.



77

CONDENSATE DRAIN CONNECTION



In cold climates with freezing weather, the condensate should not be drained to the outside as the condensate line could freeze and the heater will stop operating.



78

CONDENSATE DRAIN CONNECTION

Material of the condensate drain piping

Use plastic pipe, such as PVC, for the drain line.

NOTE Do not use steel, black iron, or any other material which can corrode when placed into contact with acidic condensate.

Sizing of the condensate drain piping

In order to drain the condensate, a 1/2 in. threaded fitting is provided at the base of the Water Heater.

NOTE Do not reduce the size of the fitting or the condensate drain piping to less than 1/2 in.

[Condensate drain piping to floor drain]

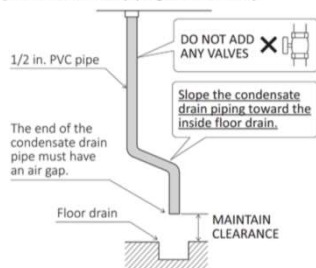

The drain line should be plastic as the acidic condensate will corrode metal pipes and the line should be no smaller than 1/2".

Horizontal runs should be sloped downward a 1/4" for every 1 foot of piping.

Make sure you leave an air gap at the end of the drain line.



79

FILLING CONDENSATE TRAP

Fill the condensate container by pouring approx. 10 oz. (280 mL) of water into the exhaust flue on the top of the Water Heater as illustrated below.

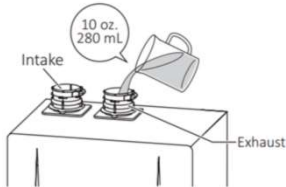

1) Fill the condensate container by pouring approx. 30 oz. (850ml) of water into the exhaust accessory on the top of the appliance as illustrated below.

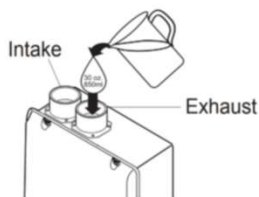

The condensate collector inside the unit that should be pre-charged with water to prevent carbon monoxide leakage during initial operation of the unit. Pre-mix models such as the EZ series need about 10 oz of water while traditional condensing units like the NRC111 need about 30 oz.



80

FILLING CONDENSATE TRAP

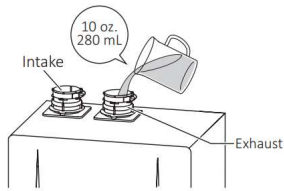

If the vent pipe has already been installed:
After installing the condensate drain pipe, make sure that the area around the Water Heater is well ventilated; open a window or a door if necessary. Then, operate the Water Heater and verify that condensate is coming out of the condensate drain pipe.
(During normal use of the Water Heater, condensate will begin to discharge from the condensate drain pipe within 15 minutes of use. However, depending on the season and/or installation site conditions, it may take longer.)

If you forget to pre-charge the condensate collector, make sure the installation area is well ventilated for the first 15-20 minutes of operation as the unit creates condensate and fills the collector.



81

NEUTRALIZING THE CONDENSATE

Condensing Water Heater

- In order to ensure proper operation of this Water Heater, need to install the condensate drain pipe to drain acidic condensate which produces during operation.
- The pH level of the condensate is approximately 2-3. An external neutralizer must be installed on the condensate drain piping prior to disposal when required by local code or when the condensate could cause damage.

NOTE Damage caused by improperly handled condensate is not covered by the Noritz America Limited Warranty.

Treating the acidic condensate created by high efficiency units may be required by local code and is a good practice even if code doesn't require it.



82

NEUTRALIZING THE CONDENSATE

[If an external neutralizer is installed]

Periodic replacement of the neutralizing agent will be required. Refer to the instructions supplied with the neutralizer for suggested replacement intervals.

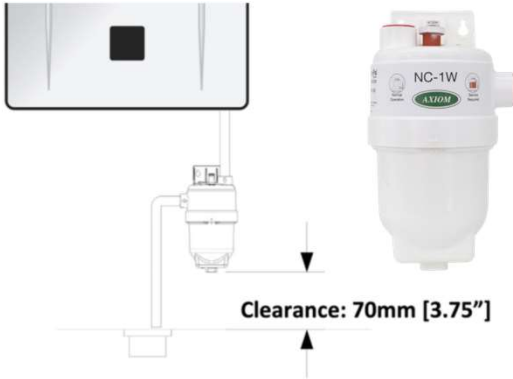

Noritz offers external neutralizers to raise the pH level of the acidic condensate to that of water so it can be drained safely.

The residential neutralizer is recommended to be installed **1** per unit.



83

EZ START PLUS APP



Pro Series models no longer have physical dipswitches on the circuit board. All programming of the unit is done with the new EZ Start Plus App or the built in Operation Panel.

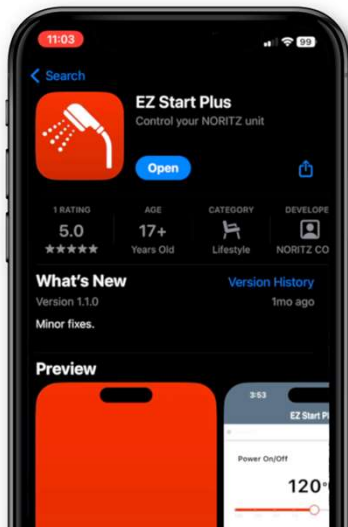

Directions can be found in the manual

84

EZ START PLUS APP

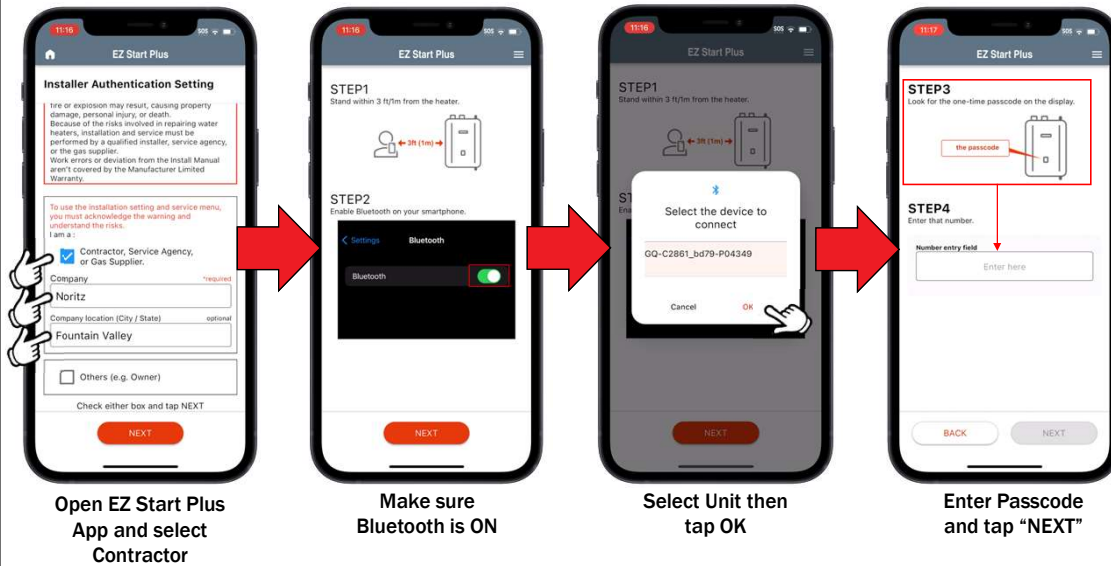

85

EZ START PLUS APP

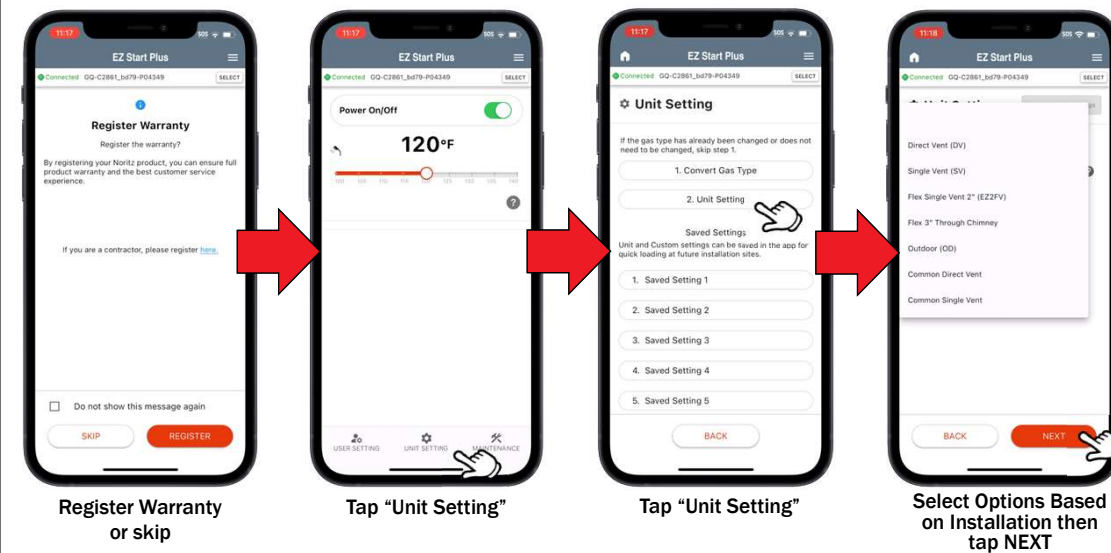

86

EZ START PLUS APP

Upon completion, email app will open to allow emailing the installation settings to Noritz. This is not required, but very helpful for Customer Care.

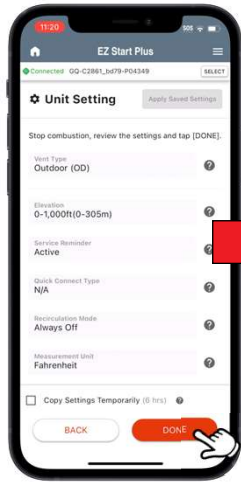

Review your selections then tap DONE

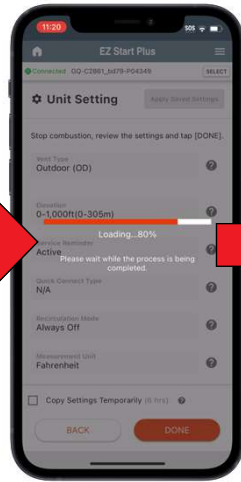

App programs unit

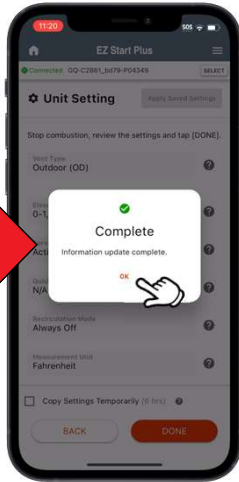

Tap OK when complete

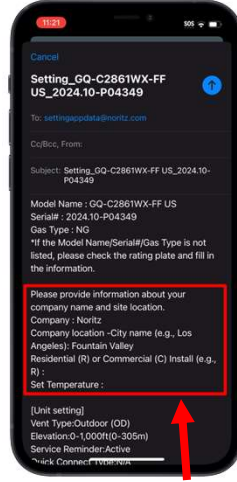

Please fill out these items if you opt in to send.

Scan Here!



SETTING THE DIPSWITCHES

DIP Switch Settings

Disconnect the electrical power to the water heater before adjusting the DIP Switches.

The following settings can be adjusted using the DIP Switches:

- To set up with the common vent system, SW 1 needs to be turned on.*
- By using SW 2 and 3, it can adapt to the setting of the exhaust type.**
- By using SW 5 and 6, adjustments can be made for use at high elevation.
- By using SW 7 and 8, adjustments can be made for extended vent lengths. Refer to the "Setting list for DIP Switches" table for details.

[DIP Switches]



Setting list for DIP Switches (● :ON ○ :OFF)

SW1	SW2	SW3	SW5	SW6	SW7	SW8
Common vent system*		Exhaust type**		Elevations above 2000ft		Vent Length Adjustment and Vent Size
SW1	SW2	SW3	SW5	SW6	High Elevation Adjustment	SW7 SW8
○	○	○	DV	○	0~2000ft (0~610m)	○ ○ 2" Short Length
●	●	○	OD	●	2001~4000ft (611~1219m)	● ○ 2" Long Length
○	○	●	SV	○	4001~7000ft (1220~2134m)	○ ● 3" Short Length
○	●	●	EZTR	●	7001~10000ft (2135~3048m)	● ● 3" Long Length

* Refer to the Installation Manual of common vent system for detail information.

** DV : Direct Vent, OD : Outdoor (using VC-6), SV : Single Vent (using SV Conversion Kit), EZTR : 2" PP Flexible Pipe (using EZ2-CK)

Non-PRO units will have 8 dipswitches located on the circuit board for adjusting the unit based on vent type, elevation, vent length and size.



SETTING THE DIPSWITCHES

■ DIP Switch Settings

*Disconnect the electrical power to the unit before adjusting the DIP Switches.

The following settings can be adjusted using the DIP Switches.

1. By setting DIP Switches 1 and 2, the unit can be programmed to different default temperatures if the remote controller is removed.
2. (-DV Model only) By setting DIP Switch 3, the intake air supply type can be set to direct vent(DV) or non-direct vent(SV).
3. By setting DIP Switches 5 and 6, adjustments can be made for high elevation installations.
4. By setting DIP Switches 7, adjustments can be made for extended vent lengths installations. Refer to the "Setting list for DIP Switches" table for details.

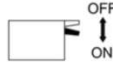
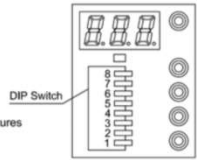

Setting list for DIP Switches

(● :ON ○ :OFF)

1		2		3		5		6		7	
Default temperature setting		Intake Air supply type -DV Model only		Elevations above 2,000ft		Vent Length Adjustment -DV(-SV) Model only					
1	2	3	Intake Air supply	5	6	High Elevation Adjustment	7	Vent Length			
○ ○	120°F (50°C)	○	Outdoor : DV	○ ○		0-2,000ft (0-610m)	○	Short Length			
● ●	130°F (54°C)	●	Indoor : SV	● ○		2,001-4,000ft (611-1,220m)	●	Long Length			
● ○	135°F (57°C)			○ ●		4,001-6,000ft (1,221-1,830m)					
○ ●	140°F (60°C)			● ●		6,001-8,000ft (1,831-2,440m)					

note) The unit is fixed with minimum combustion, if you change No.4 to ON. It is possible to cause the trouble, please do not change it. No.8 does not have any function.

On smaller units that don't include a remote control, the dipswitches will also allow you to set the output temperature above the default 120 degrees F.



89

SETTING THE DIPSWITCHES



Be sure to make dipswitch changes with the power off otherwise an error code 73 will occur.



90

SETTING THE DIPSWITCHES



EC73
TECH TIP
VIDEO



To Clear EC73:

- Disconnect Power
- Make Dipswitch Changes
- Reconnect Power



91

SETTING DIPSWITCHES WITH PROCARD

Use the PROCard App to make dipswitch settings simple!

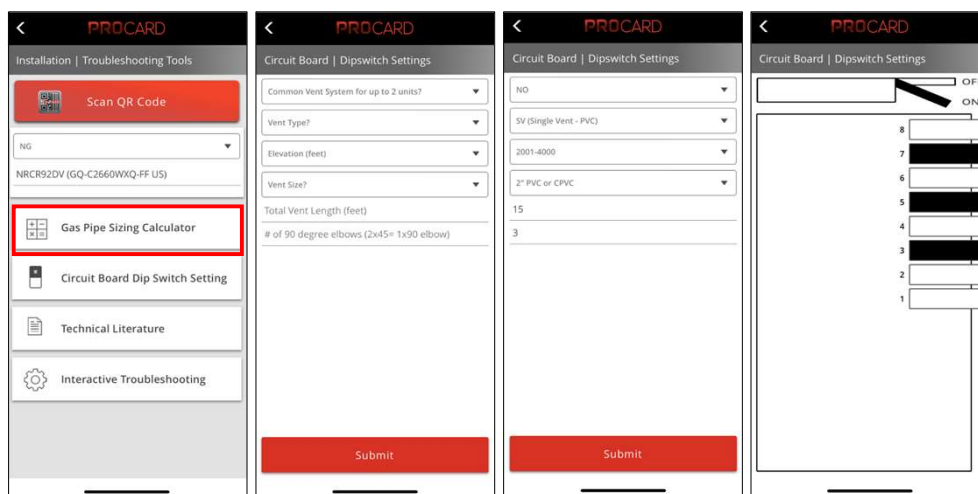

92

WATER QUALITY CONSIDERATIONS



Water quality, and specifically hard water, is the #1 factor that affects the lifespan of any water heating appliance.



93

WATER QUALITY CONSIDERATIONS

8.3 Water Treatment

If this Water Heater will be installed in a location where the hardness of the supply water is high, scale Build-up may cause damage to the Heat Exchanger. Perform suggested treatment and maintenance measures to be taken based on the water hardness level according to the below table.

Treatment Guidelines

Type of Water	Hardness Level	Treatment Device*	Flush Frequency**
Soft	0-1 gpg (0-17 mg/L)	None	None
Slightly Hard	1-3 gpg (17-51 mg/L)		
Moderately Hard	3-7 gpg (51-120 mg/L)	Scale Shield or Water Softener	Once a Year***
Hard	7-10 gpg (120-171 mg/L)		
Very Hard	10-12 gpg (171-200 mg/L)		
Extremely Hard	> 12 gpg (> 200 mg/L)		

* When selecting a treatment device, you must consult with the device's spec sheet and installation manual for guidelines and limitations. Not all water supplies are compatible. A water test may be required.
 ** Install Noritz Isolation Valves to allow for flushing.
 *** Flushing is required if a water treatment device is not installed.

NOTE Damage to the Water Heater as a result of the items below is not covered by the Noritz America Limited Warranty.

- Water in excess of 12 gpg (200 mg/L) of hardness
- Poor water quality (See the Water Quality List on page 12.)
- The Remote Controller has displayed a "C1# (Service Reminder)" indicating Scale Build-up, but the Heat Exchanger has not been flushed.

When installing a Noritz Tankless in an area with hard water, it's important to follow the water quality and treatment guidelines in the installation manual.



94

WATER QUALITY CONSIDERATIONS



A Scale Shield is highly recommended for hard water areas. It's always better to prevent scale build up rather than cleaning it up afterwards.



95

WATER QUALITY CONSIDERATIONS



As a last resort if there's no softener or scale shield, descales should be completed on a yearly basis. This involves circulating a calcium lime rust remover or food grade white vinegar through the unit for 1 hour.



96

WATER QUALITY CONSIDERATIONS

All* units since 2016 have a “Flush Mode” used when descaling the unit.

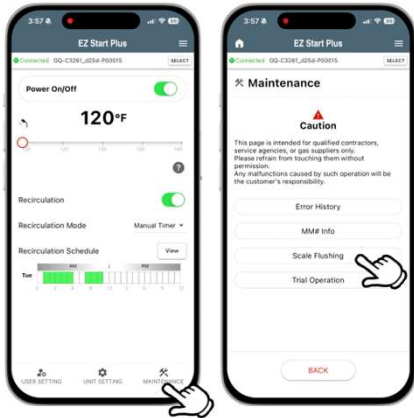

PRO Series Models



Directions can be found in the manual

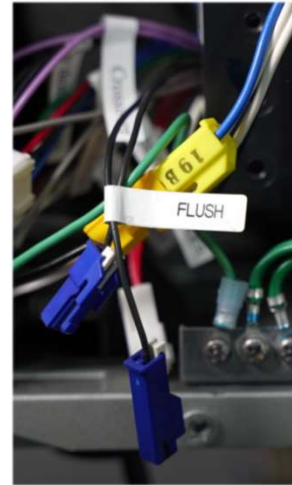

2016+ Models



*NC380-SV Does not have a flush connector.

97

WATER QUALITY CONSIDERATIONS

Descale procedures can be found:

- In the Manual
- In the PROCard App
- SUPPORT.NORITZ.COM
- YOUTUBE.COM/NORITZAMERICA



98

INSTALLATION CHECKLIST

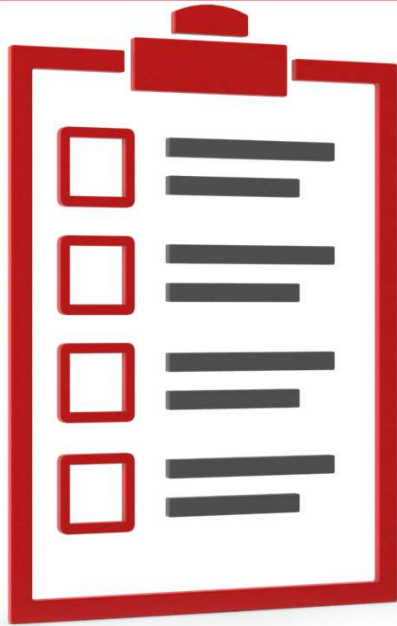

Before leaving the jobsite and calling the installation complete, it's a good practice to verify everything is working properly.



99

INSTALLATION CHECKLIST

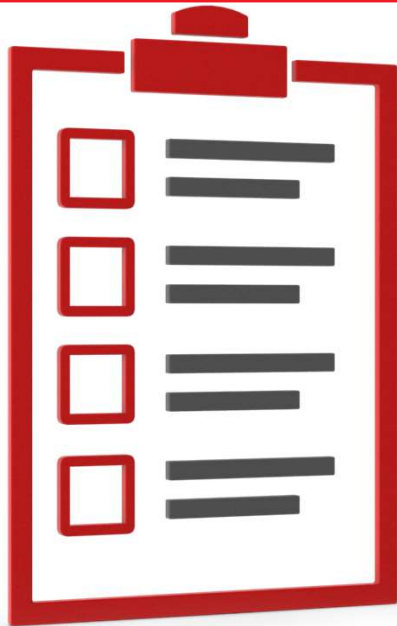

This includes, but is not limited to:

- Double check unit settings
 - EZ Start App or Operation Panel for Pro Series
 - Dipswitches for other models
- Checking inlet water filter
- Testing the heater at low, moderate and high flow rates for a few minutes
- Registering the warranty



100

REGULAR MAINTENANCE ITEMS



To keep the tankless running at peak performance and efficiency throughout its life, here are a few other regular maintenance items to keep in mind.

- Cleaning the unit and combustion chamber if excessive build up is noticed.
- Cleaning the ignition and flame rods.
- Checking and cleaning the cold water inlet filter.



101

REGULAR MAINTENANCE ITEMS

Encourage your customers to visually check the unit once in awhile.

Tankless heaters, like any other gas appliance, are not meant to be installed and forgotten about.



102

REGULAR MAINTENANCE ITEMS



Periodically inspecting the unit for any minor issues will help prevent it from becoming a bigger problem.



103

HELPFUL CONTACT INFO

866-7NORITZ (866-766-7489)

- Monday – Friday: 5am to 6pm PST
- Saturday: 6am to 3pm PST



EZ Start Plus App



Gas Conversion



SUPPORT.NORITZ.COM



NORITZ.COM/TECHTIPS



HELP.NORITZ.COM



TRAINING.NORITZ.COM



YOUTUBE.COM/
NORITZAMERICA



PROCARD.NORITZ.COM



104

THANK YOU

